

REPRODUCED FROM ORDNANCE SURVEY MAPS WITH PERMISSION FROM THE CONTROLLER OF HM STATIONERY OFFICE. CROWN COPYRIGHT RESERVED. LICENCE NO. 100023422 2007.

- GENERAL NOTES**
- DO NOT SCALE FROM THIS DRAWING.
  - ALL DIMENSIONS ARE IN MILLIMETRES UNLESS NOTED OTHERWISE.
  - ALL LEVELS ARE IN METRES RELATIVE TO ORDNANCE DATUM NEWLYN UNLESS NOTED OTHERWISE.
  - THIS DRAWING HAS BEEN BASED UPON SURVEY / OS INFORMATION SUPPLIED BY INTERLOCKS SURVEYS LIMITED. ROYAL HASKONING DHV SHALL NOT BE LIABLE FOR ANY INACCURACY OR DEFICIENCIES ARISING FROM IT.
  - THIS DRAWING TO BE READ IN CONJUNCTION WITH ALL OTHER RELEVANT DRAWINGS.
  - ALL MATERIALS AND WORKMANSHIP WILL BE AS SPECIFIED IN THE SPECIFICATION UNLESS NOTED OTHERWISE.
  - ALL LEVELS, DIMENSIONS AND LOCATIONS ARE TO BE CHECKED BY THE MAIN CONTRACTOR PRIOR TO COMMENCEMENT OF ANY WORK ON SITE.

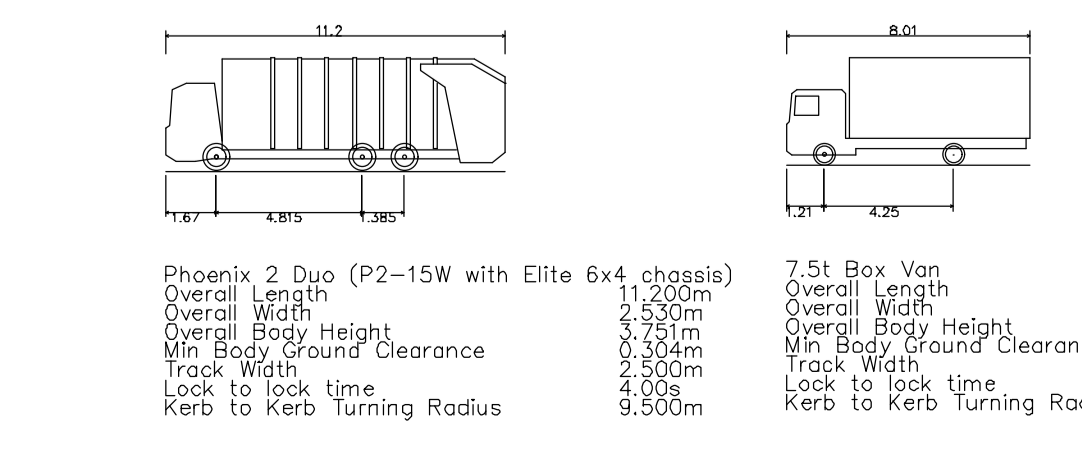

NO	DATE	DESCRIPTION	BY	CHK	APP
003	04/02/20	UPDATED AS PER HA JANUARY COMMENTS	JBW	PV	DJ
002	06/07/18	ROAD LAYOUT UPDATED	BKB	PV	DJ
001	06/06/18	FIRST ISSUE	LZ	PV	DJ

CLIENT	PROJECT	TITLE
REDROW	GREAT WILSEY PARK	RESERVED MATTERS SWEEP PATH LARGE VEHICLES



DATE	SCALE AT AGE	REVISION NUMBER
OCT-18	1:250	PB8301

**Royal HaskoningDHV**  
Enhancing Society Together

Drawn: LZ, Checked: PV, Approved: DJ  
Date: OCT-18, Scale at Age: 1:250, Project Number: PB8301  
Drawing No: PB8301-RHD-DE-H1-DR-D-0211, Revision: 103