

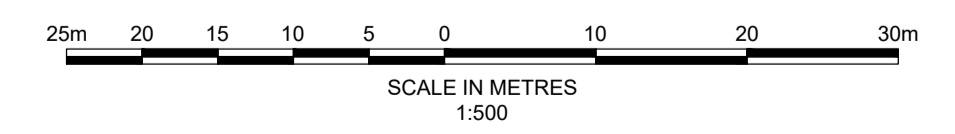

REPRODUCED FROM ORDNANCE SURVEY MAPS WITH PERMISSION FROM THE CONTROLLER OF HM STATIONERY OFFICE. CROWN COPYRIGHT RESERVED. LICENCE No. 100023422 2007.

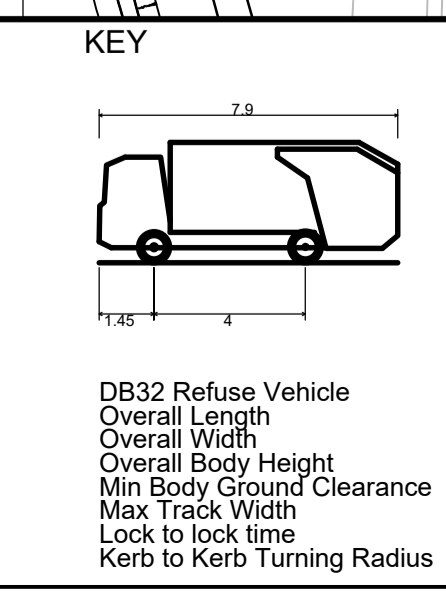

- GENERAL NOTES**
- DO NOT SCALE FROM THIS DRAWING.
 - ALL DIMENSIONS ARE IN MILLIMETRES UNLESS NOTED OTHERWISE.
 - ALL LEVELS ARE IN METRES RELATIVE TO ORDNANCE DATUM NEWLYN UNLESS NOTED OTHERWISE.
 - THIS DRAWING HAS BEEN BASED UPON SURVEY / OS INFORMATION SUPPLIED BY INTERLOCKS SURVEYS LIMITED. ROYAL HASKONING DHV SHALL NOT BE LIABLE FOR ANY INACCURACY OR DEFICIENCIES ARISING FROM IT.
 - THIS DRAWING TO BE READ IN CONJUNCTION WITH ALL OTHER RELEVANT DRAWINGS.
 - ALL MATERIALS AND WORKMANSHIP WILL BE AS SPECIFIED IN THE SPECIFICATION UNLESS NOTED OTHERWISE.
 - ALL LEVELS, DIMENSIONS AND LOCATIONS ARE TO BE CHECKED BY THE MAIN CONTRACTOR PRIOR TO COMMENCEMENT OF ANY WORK ON SITE.



- OUTLINE APPLICATION BOUNDARY
- HOUSING RMA APPLICATION BOUNDARY

REV	DATE	DESCRIPTION	BY	CHK	APP
P06	14/08/20	UPDATED TO LATEST ARCHITECT'S LAYOUT	JBW	PV	DJ
P05	22/09/20	AMENDED FOLLOWING CLIENT COMMENTS	MB	PV	DJ
P04	16/09/20	AMENDED FOLLOWING CLIENT COMMENTS	MB	PV	DJ
P03	01/04/20	UPDATED TO LATEST ARCHITECT'S LAYOUT	JBW	PV	DJ
P02	19/03/20	UPDATED TO LATEST ARCHITECT'S LAYOUT	JBW	PV	DJ
P01	13/09/19	FIRST ISSUE	JBW	PV	DJ

REVISED BY: CHW, AMB

DRAWING STATUS: **PRELIMINARY**



RESERVED MATTERS
A2

REFUSE VEHICLE
SWEPT PATH ANALYSIS

Royal HaskoningDHV
Enhancing Society Together

Postland Street, Manchester One, 5th Floor
M1 2JL Manchester, UK
Email: info.manchester@uk.rdhv.com
Website: www.rdhv.com

DRAWN	CHECKED	APPROVED
JBW	PV	DJ
DATE	SCALE	PROJECT NUMBER
SEP '19	1:500	PB8301
DRAWING NO.	REVISION	
PB8301-RHD-DE-A2-DR-D-0211	P06	