

NOTE: - ALL HANDINGS ARE VIEWED FROM DRIVE SIDE. LEFT HAND ROTATIONS ARE DIRECT MIRROR IMAGE

DISCHARGE FLANGE DETAIL

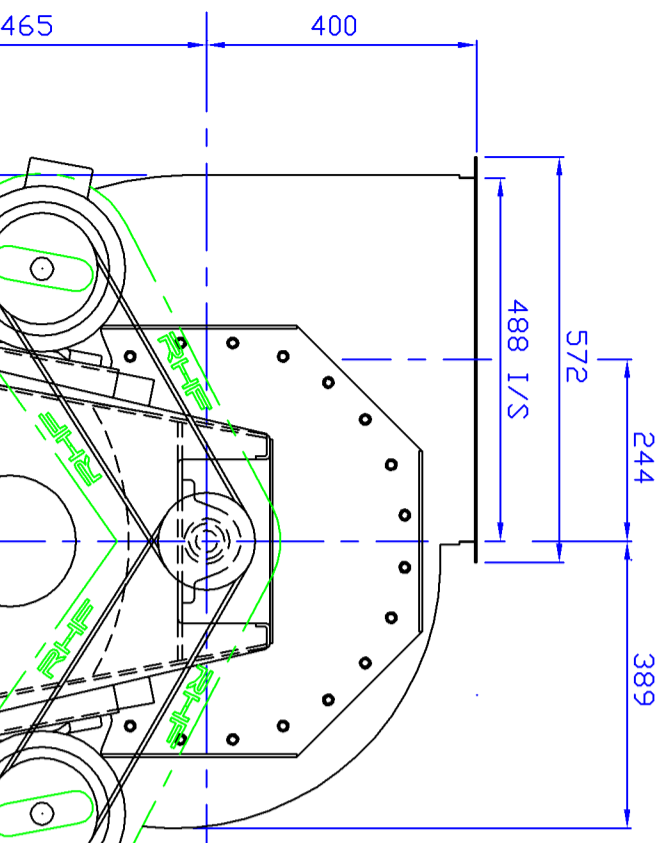

16 HOLES Ø12
EQUI-SPACED
OFF CTRS DN
A 550 PCD

6 HOLES Ø14

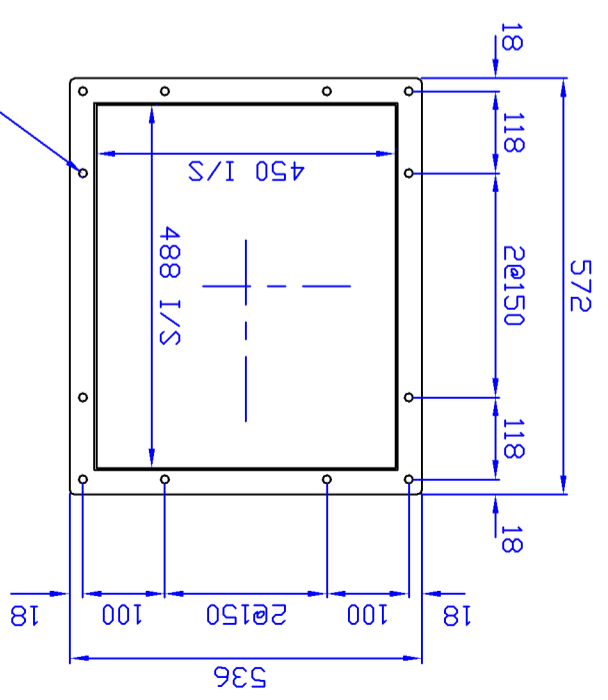
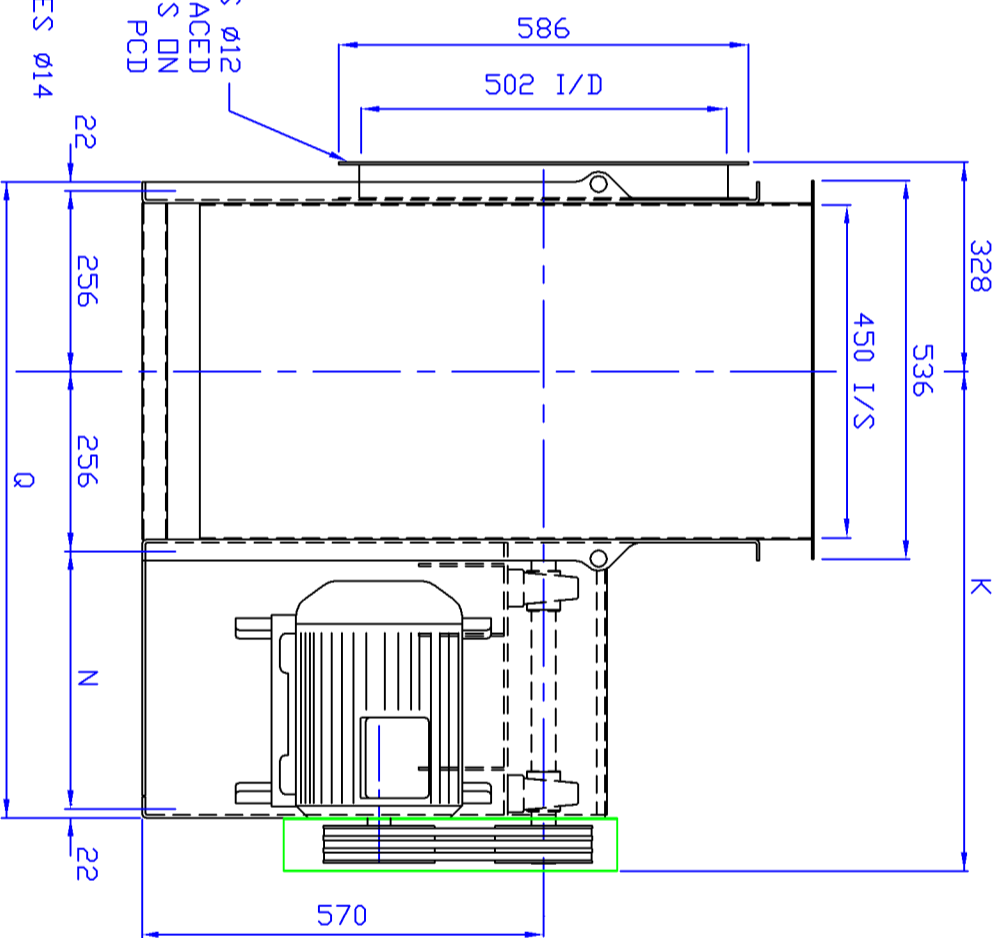

16 HOLES Ø12

MOTOR FRAME SIZE	N	Ø	K
- 132M	420	976	818
160M - 160M	500	1056	918

NOTE: - MOTOR POSITION "A" LHS OF PEDESTAL (AS SHOWN) / POSITION "B" RHS (AVAILABLE)

NOTE: - MOTOR TERMINAL BOX POSITION MAY VARY FROM THAT AS SHOWN DEPENDING ON MOTOR MANUFACTURER

ORDER DETAILS		FAN FEATURES & ANCILLARY ITEMS SUPPLIED ON THIS ORDER		DRIVE DETAILS		MOTOR DETAILS	
CUSTOMER NAME:-	CCASWELL ENGINEERING SERVICES LTD	INLET SPIGOT / DISCHARGE FLANGE	DDV CORNING 736 SEALANT	FAN PULLEY:-	140 * 2DA	Make:-	WEG ELECTRIC
CUSTOMER D/No:-	P00009421	ACC.DDRR XL x2/DRAIN PLUG		FAN BUSH:-	2012/35	Kw:-	5.50
DATE:-	06/01/12	DUAL VEE BELT/DRIVE GUARD		MOTOR PULLEY:-	180 * 1DA	rpm:-	1470
DUTY:-	2.8 m3/Sec @ 1200 Pascal @ 20°C	MOTORx2/ADJ. MOTOR PLx 2		MOTOR BUSH:-	1610/38	Supply:-	400-3-50
MAX TEMP:-	50 °C	MILD STEEL CONSTRUCTION		BELTS:-	2SPA 1332	Encl:-	TEFC / EFF1
HANDING/MOTOR POSITION:-	L O A & B	Powd. Coat BS 10-A-11		CTR DIST:-	414	Frame:-	D132S

UNIT 2, FERROUS WAY
GILCHRIST ROAD
NORTHBANK IND. PARK
IRLAM, MANCHESTER
M44 5FS
TEL:- 0161-776 6400
FAX:- 0161-775 6566

ISSUE	DESCRIPTION	D.F.	D.F.	DATE
A	Initial Release			

TITLE
BW 500
No9 Monoblock Dual Drive
RHF DRG. No. INV11NUGSTBF1HAL01

RHF FANS LTD