

(HW3)
R18B 01 1150 HEADWALL (ATHLON)
WITH ATTACHED ORIFICE PLATE

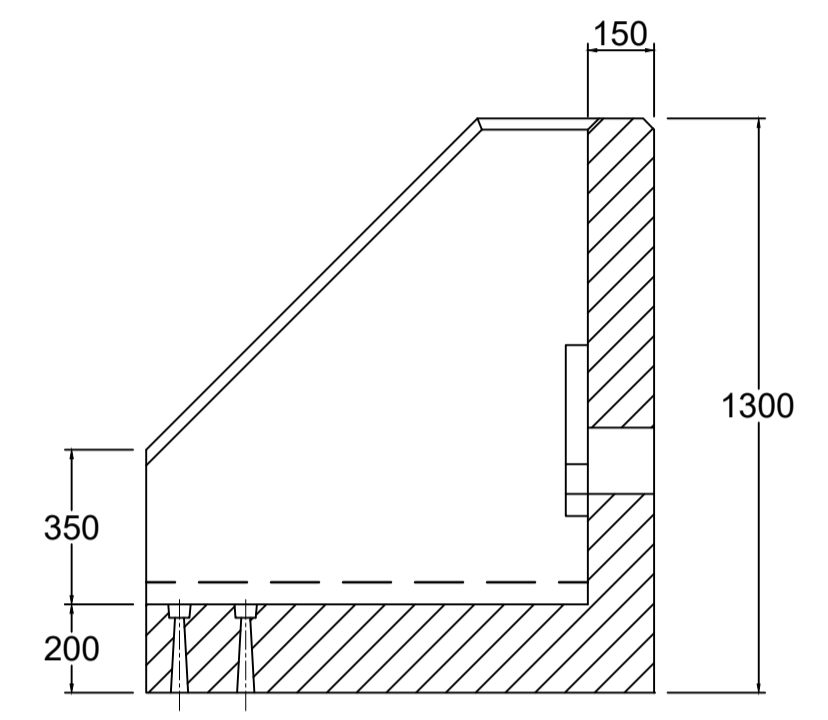

NOTES

- THIS DRAWING IS TO BE READ IN CONJUNCTION WITH ALL RELEVANT ENGINEERS, ARCHITECTS AND SPECIALISTS DRAWINGS AND THE SPECIFICATION.
- DO NOT SCALE FROM THIS DRAWING MANUALLY OR ELECTRONICALLY. WRITTEN PERMISSION MUST BE OBTAINED FROM MLM PRIOR TO SCALING ELECTRONICALLY OR USING THIS ELECTRONIC FILE.

CONSTRUCTION (DESIGN AND MANAGEMENT) REGULATIONS 2015

DESIGNERS HAZARD INFORMATION FOR CONSTRUCTION

- IF YOU DO NOT FULLY UNDERSTAND THE RISKS INVOLVED DURING THE CONSTRUCTION OF THE ITEMS INDICATED ON THIS DRAWING ASK YOUR MANAGER, HEALTH & SAFETY ADVISOR OR A MEMBER OF THE DESIGN TEAM BEFORE PROCEEDING.
- WORKS ADJACENT TO LIVE PUBLIC HIGHWAY.
- DEEP EXCAVATIONS.
- WORKING WITH OPEN WATER.
- EXISTING SERVICES.
- DEEP DRAINAGE.

THE ABOVE NOTES REFER SPECIFICALLY TO THE INFORMATION SHOWN ON THIS DRAWING.

REFER TO THE HEALTH AND SAFETY PLAN FOR FURTHER INFORMATION.

T02	07.11.2019	HEADWALLS LABELED	DS	DK	DK
T01	11.10.2019	FIRST ISSUE	DS	SJ	DK
REV	DATE	REVISION	MADE	CHK	APP

DRAWING STATUS: **TENDER**

SUITABILITY DESCRIPTION: **SUITABLE FOR INFORMATION**

Connect 38,
1 Dover Place, Ashford,
Kent, TN23 1FB
Tel: 01233 610530
Website: www.mlmgroupp.com

MLM Group
Part of Sweco

CLIENT: **PERSIMMON**

PROJECT: **NORTHWEST HAVERHILL RELIEF ROAD**

DRAWING TITLE: **SURFACE WATER DRAINAGE CONSTRUCTION DETAILS**

DRAWN/DESIGN	DS	MLM REF	STATUS	REVISION
SCALE	1:500 @A1	619132	S2	T02
PROJECT	ORIGINATOR	VOLUME/ LEVELS & LOCATIONS	TYPE	ROLE
619132-MLM-ZZ-XX-DR-C-0200				NUMBER

