

| CBR Value      | Sub-base thickness (mm) |
|----------------|-------------------------|
| 5% and greater | 225                     |
| 4%             | 300                     |
| 3%             | 350                     |
| 2%             | 400                     |
| less than 2%   | refer to Engineer       |

\* Note that the minimum total carriageway thickness is 450mm due to sub-grade being frost susceptible

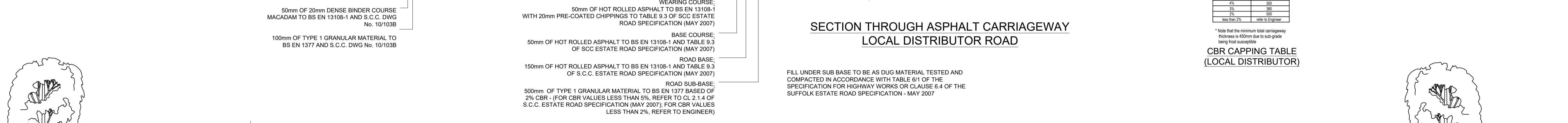

| CBR Value      | Sub-base thickness (mm) |
|----------------|-------------------------|
| 5% and greater | 225                     |
| 4%             | 270                     |
| 3%             | 300                     |
| 2%             | 400                     |
| less than 2%   | refer to Engineer       |

\* Note that the minimum total carriageway thickness is 450mm due to sub-grade being frost susceptible

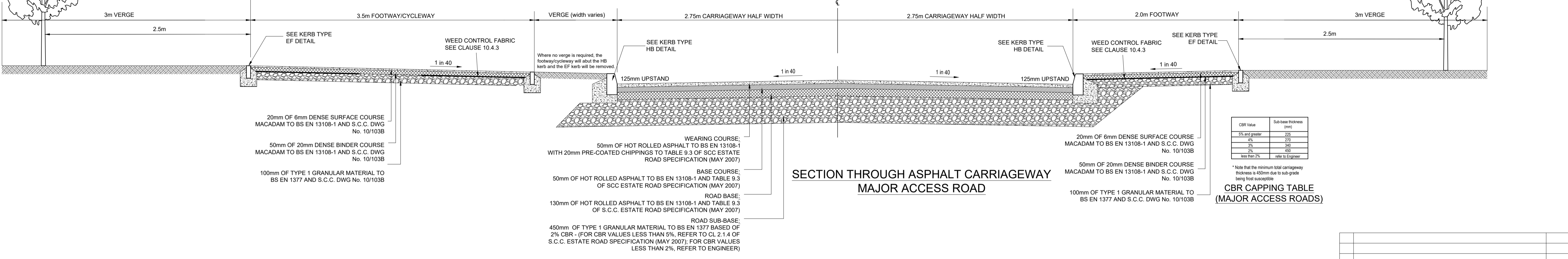

| CBR Value      | Sub-base thickness (mm) |
|----------------|-------------------------|
| 5% and greater | 225                     |
| 4%             | 270                     |
| 3%             | 300                     |
| 2%             | 400                     |
| less than 2%   | refer to Engineer       |

\* Note that the minimum total carriageway thickness is 450mm due to sub-grade being frost susceptible

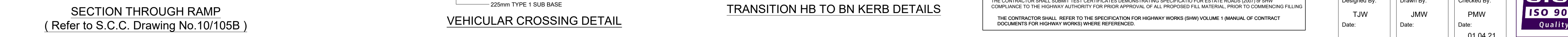
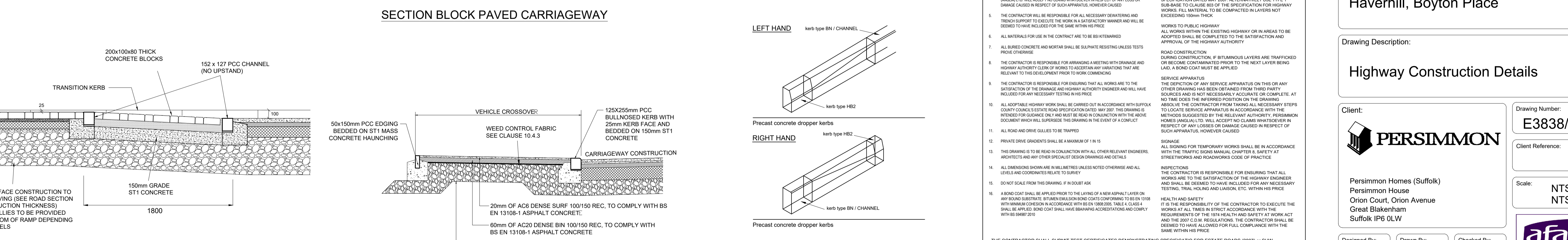
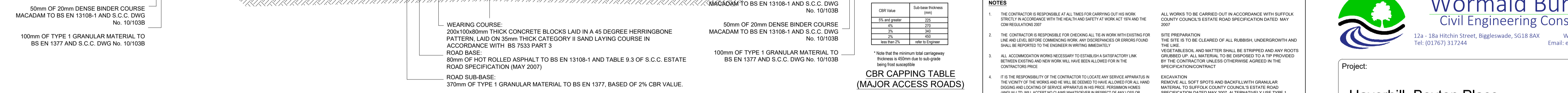
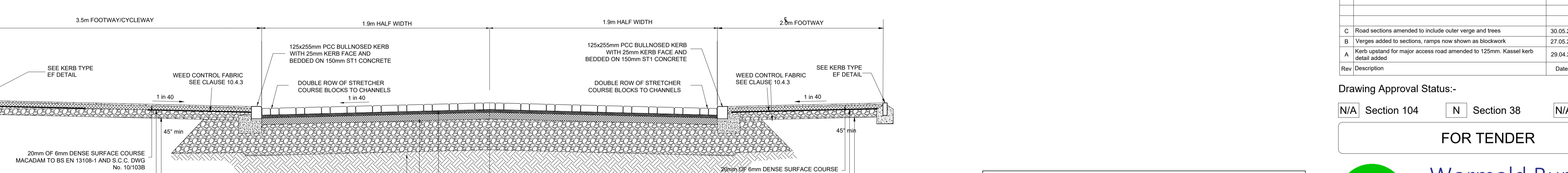

**NOTES**

- THE CONTRACTOR IS RESPONSIBLE FOR CARRYING OUT HIS WORK STRICTLY IN ACCORDANCE WITH THE HEALTH AND SAFETY AT WORK ACT 1974 AND THE CDM REGULATIONS 2007
- THE CONTRACTOR IS RESPONSIBLE FOR CHECKING ALL THE WORK WITH REGARD TO LINE AND LEVEL BEFORE COMMENCING WORK. ANY DISCREPANCIES OR ERRORS FOUND SHALL BE REPORTED TO THE ENGINEER IN WRITING IMMEDIATELY
- ALL ACCOMMODATION WORKS NECESSARY TO ESTABLISH A SATISFACTORY LINK BETWEEN EXISTING AND NEW WORK WILL BE ALLOWED FOR IN THE CONTRACTOR'S PRICE
- IT IS THE RESPONSIBILITY OF THE CONTRACTOR TO LOCATE ANY SERVICE APPARATUS IN THE VICINITY OF THE WORKS AND HE WILL BE DEEMED TO HAVE ALLOWED FOR ALL HAND DIGGING AND LOCATING OF SERVICE APPARATUS IN HIS PRICE. PERSIMMON HOMES (ANGLIA) LTD WILL ACCEPT NO CLAIMS WHATSOEVER IN RESPECT OF ANY LOSSES OR DAMAGE CAUSED IN RESPECT OF SUCH APPARATUS, HOWEVER CAUSED
- THE CONTRACTOR WILL BE RESPONSIBLE FOR ALL NECESSARY DENATURING AND TRENCH SUPPORT TO COMPLETE THE WORK IN A SATISFACTORY MANNER AND WILL BE DEEMED TO HAVE INCLUDED FOR THE SAME WITHIN HIS PRICE
- ALL MATERIALS FOR USE IN THE CONTRACT ARE TO BE BS1 KETAMARKED
- ALL BURED CONCRETE AND MORTAR SHALL BE SULPHATE RESISTING UNLESS TESTS PROVE OTHERWISE
- THE CONTRACTOR IS RESPONSIBLE FOR ARRANGING A MEETING WITH DRAINAGE AND HIGHWAY AUTHORITY CLERK OF WORKS TO ASCERTAIN ANY VARIATIONS THAT ARE RELEVANT TO THIS DEVELOPMENT PRIOR TO WORK COMMENCING
- THE CONTRACTOR IS RESPONSIBLE FOR ENSURING THAT ALL WORKS ARE TO THE SATISFACTION OF THE DRAINAGE AND HIGHWAY AUTHORITY ENGINEER AND WILL HAVE INCLUDED FOR ANY NECESSARY TESTING IN HIS PRICE
- ALL ADAPTABLE HIGHWAY WORK SHALL BE CARRIED OUT IN ACCORDANCE WITH SUFFOLK COUNTY COUNCIL'S ESTATE ROAD SPECIFICATION DATED MAY 2007. THIS DRAWING IS INTENDED FOR GUIDANCE ONLY AND MUST BE READ IN CONJUNCTION WITH THE ABOVE DOCUMENT WHICH WILL SUPERSEDE THIS DRAWING IN THE EVENT OF A CONFLICT
- ALL ROAD AND DRIVE GULLIES TO BE TRAPPED
- PRIVATE DRIVE GRADIENTS SHALL BE A MAXIMUM OF 1 IN 15
- THIS DRAWING IS TO BE READ IN CONJUNCTION WITH ALL OTHER RELEVANT ENGINEERS, ARCHITECTS AND ANY OTHER SPECIALIST DESIGN DRAWINGS AND DETAILS
- ALL DIMENSIONS SHOWN ARE IN MILLIMETRES UNLESS NOTED OTHERWISE AND ALL LEVELS AND COORDINATES RELATE TO SURVEY
- DO NOT SCALE FROM THIS DRAWING. IF IN DOUBT ASK
- A ROAD COAT SHALL BE APPLIED PRIOR TO THE LAYING OF A NEW ASPHALT LAYER ON ANY ROAD SUBSTRATE. SUBSTRATE EMULSION BOND COATS CONFORMING TO BS EN 10138 WITH MINIMUM COHERION IN ACCORDANCE WITH BS EN 13300:2005, TABLE 4, CLASS 4 SHALL BE APPLIED. BOND COAT SHALL HAVE BSAHAPS ACCREDITATION AND COMPLY WITH BS 5987:2010

ALL WORKS TO BE CARRIED OUT IN ACCORDANCE WITH SUFFOLK COUNTY COUNCIL'S ESTATE ROAD SPECIFICATION DATED MAY 2007

**SITE PREPARATION**  
THE SITE IS TO BE CLEARED OF ALL RUBBISH, UNDERGROWTH AND THE LIKE. VEGETABLES AND MATTER SHALL BE STRIPPED AND ANY ROOTS ORNAMENTED UP. ALL MATERIAL TO BE DISPOSED TO A TIP PROVIDED BY THE CONTRACTOR UNLESS OTHERWISE AGREED IN THE SPECIFICATION CONTRACT

**EXCAVATION**  
REMOVE ALL SOFT SPOTS AND BACKFILL WITH GRANULAR MATERIAL TO SUFFOLK COUNTY COUNCIL'S ESTATE ROAD SPECIFICATION DATED MAY 2007. ALTERNATIVELY USE TYPE 1 SUB-BASE TO CLAUSE 603 OF THE SPECIFICATION FOR HIGHWAY WORKS. FILL MATERIAL TO BE COMPACTED IN LAYERS NOT EXCEEDING 150mm THICK

**WORKS TO PUBLIC HIGHWAY**  
ALL WORKS WITHIN THE EXISTING HIGHWAY OR IN AREAS TO BE ADOPTED SHALL BE COMPLETED TO THE SATISFACTION AND APPROVAL OF THE HIGHWAY AUTHORITY

**ROAD CONSTRUCTION**  
DURING CONSTRUCTION, IF BITUMINOUS LAYERS ARE TRAFFICED OR BECOME CONTAMINATED PRIOR TO THE NEXT LAYER BEING Laid, A BOND COAT MUST BE APPLIED

**SERVICE APPARATUS**  
THE DEPICTION OF ANY SERVICE APPARATUS ON THIS OR ANY OTHER DRAWING HAS BEEN OBTAINED FROM THIRD PARTY SOURCES AND IS NOT NECESSARILY ACCURATE OR COMPLETE. AT NO TIME DOES THE INFERRED POSITION ON THE DRAWING ABOVE THE CONTRACTOR FROM TAKING ALL NECESSARY STEPS TO LOCATE SERVICE APPARATUS IN ACCORDANCE WITH THE METHODS SUGGESTED BY THE RELEVANT AUTHORITY. PERSIMMON HOMES (ANGLIA) LTD WILL ACCEPT NO CLAIMS WHATSOEVER IN RESPECT OF ANY LOSSES OR DAMAGE CAUSED IN RESPECT OF SUCH APPARATUS, HOWEVER CAUSED

**SIGNAGE**  
ALL SIGNING FOR TEMPORARY WORKS SHALL BE IN ACCORDANCE WITH THE TRAFFIC SIGNING MANUAL CHAPTER 10, SAFETY AT STREETWORKS AND ROADWORKS CODE OF PRACTICE

**INSPECTIONS**  
THE CONTRACTOR IS RESPONSIBLE FOR ENSURING THAT ALL WORKS ARE TO THE SATISFACTION OF THE HIGHWAY ENGINEER AND SHALL BE DEEMED TO HAVE INCLUDED FOR ANY NECESSARY TESTING, TRIAL HOLDING AND LIAISON, ETC. WITHIN HIS PRICE

**HEALTH AND SAFETY**  
IT IS THE RESPONSIBILITY OF THE CONTRACTOR TO EXECUTE THE WORKS AT ALL TIMES IN STRICT ACCORDANCE WITH THE REQUIREMENTS OF THE HEALTH AND SAFETY AT WORK ACT AND THE 2007 C.O.M. REGULATIONS. THE CONTRACTOR SHALL BE DEEMED TO HAVE ALLOWED FOR FULL COMPLIANCE WITH THE SAME WITHIN HIS PRICE

THE CONTRACTOR SHALL SUBMIT TEST CERTIFICATES DEMONSTRATING SPECIFICATION FOR ESTATE ROADS (2007) or SHW COMPLIANCE TO THE HIGHWAY AUTHORITY FOR PRIOR APPROVAL OF ALL PROPOSED FILL MATERIAL, PRIOR TO COMMENCING FILLING

THE CONTRACTOR SHALL REFER TO THE SPECIFICATION FOR HIGHWAY WORKS (SHW) VOLUME 1 (MANUAL OF CONTRACT DOCUMENTS FOR HIGHWAY WORKS) WHERE REFERENCED.

| Rev | Description   | Date     | Drawn | Checked |
|-----|---|----------|-------|---------|
| C   | Road sections amended to include outer verge and trees                        | 30.05.22 | LAM   | LAM     |
| B   | Verge added to sections, ramps now shown as blockwork                         | 27.05.22 | LAM   | LAM     |
| A   | Kerb upstand for major access road amended to 125mm. Kassal kerb detail added | 29.04.21 | AG    | PMW     |

Drawing Approval Status:-  
 N/A Section 104    N Section 38    N/A Section 278

**FOR TENDER**

**Wormald Burrows**  
Civil Engineering Consultants  
12a - 18a Hitchin Street, Biggleswade, SG18 8AX  
Tel: (01767) 317244    Web: www.wormburp.com    Email: engineer@wormburp.com

Project:  
**Haverhill, Boyton Place**

Drawing Description:  
**Highway Construction Details**

Client:  
**PERSIMMON**

Persimmon Homes (Suffolk)  
Orion Court, Orion Avenue  
Great Blakenham  
Suffolk IP6 0LW

Designed By: TJW  
Date:

Drawn By: JMW  
Date:

Checked By: PMW  
Date: 01.04.21

Drawing Number: **E3838/780/C**

Client Reference:

Scale: **NTS @ A1**  
**NTS @ A3**

afaq ISO 9001 Quality    UKAS MANAGEMENT SYSTEMS 622

©This drawing is Copyright, Wormald Burrows Partnership Limited 2018.    Certified by Afnor UK