

**Tracking Location Plan**  
Scale 1:500

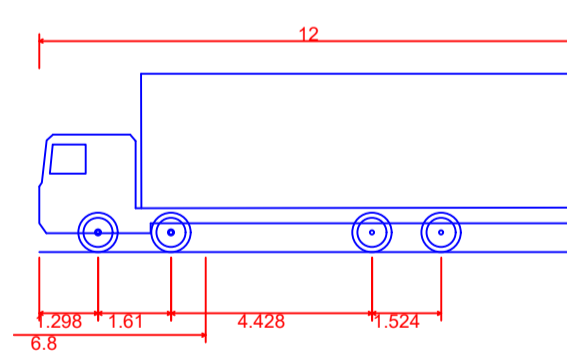

**12m Rigid Delivery Lorry Tracking Plan**  
Scale: 1:200



**Rigid Truck**  
 Overall Length 12.000m  
 Overall Width 2.500m  
 Overall Body Height 3.928m  
 Min Body Ground Clearance 0.412m  
 Track Width 2.471m  
 Lock to lock time 6.00s  
 Kerb to Kerb Turning Radius 11.900m

**12m Rigid Delivery Lorry Schematic**

Note & Key

**Tracking Key:**

- Tracking - wheel extents
- Tracking - overhang extents

Rev	Description	By	Date



Persimmon Homes Suffolk  
 Orion Court, Orion Avenue  
 Great Blakenham  
 Suffolk, IP6 0LW  
 Tel: 01473 927400

Site Name:

**Haverhill  
 Phase 3A  
 Suffolk**

Drawing:

**Commercial Delivery  
 Rigid Lorry Tracking Plan**

Scale@A1: As shown	Date: 26/11/24
Drawn By: BS	Checked By: -
Drawing No: <b>046-E-SK31</b>	Rev: -