



EXTERIOR LIGHTING DESIGN AND IMPACT ASSESSMENT

On Behalf Of

RED RAVEN SOLUTIONS LIMITED

for

**HAVERHILL PADEL COURTS, THE NEW CROFT,
CHALKSTONE WAY, HAVERHILL, CB9 0BW**

REPORT DATE: 2ND JULY 2025

REPORT NUMBER: LA103353

**Miller Goodall Ltd
Ashworth House
Deakins Business Park
Blackburn Road
Egerton
Bolton, Lancashire
BL7 9RP
Tel: 01204 596166
www.millergoodall.co.uk**

Company registration number 5201673

Summary

An exterior lighting design and associated light impact assessment have been prepared to accompany a planning application for three padel courts at The New Croft, Chalkstone Way, Haverhill, CB9 0BW.

Lighting for each padel court is required. The site is located in the urban area and part of the wider sports complex known as The New Croft – Haverhill Community Sports Association. The site is considered to reside in Environmental Zone E3 ‘medium district brightness, urban’.

The courts will be used during the evening, and all lighting will be switched off from 22:00. A canopy will be provided over the padel courts, reducing outward light spill and resolving glare issues from external viewpoints.

The lighting design has been prepared to demonstrate that the development meets the lighting requirements set by the Lawn Tennis Association for a recreational use padel court. Details of the lighting design, positioning and illuminance (lux) contour plots are appended to this report. Various best practices and embedded design mitigation measures have been included during the design process to control light and reduce levels of light spill.

Illuminance light spill contour plots and an impact assessment to consider horizontal and vertical lux levels at surrounding human sensitive receptors have been completed. The impact assessment indicates there will be no adverse effects on surrounding sensitive receptors and the overall effect of lighting can be concluded as not significant.

There is, therefore, no reason for this application to be refused on the grounds of lighting.

Prepared By	Philip Walton	Reviewed By	Lesley Goodall
Signed		Signed	
Date	2nd July 2025	Date	2nd July 2025

Version	Date	Change	Initials
1	2nd July 2025	First issue	PW

Contents

- Summary 1**
- Contents 2**
- 1 Introduction 4**
- 2 Site Description 4**
- 3 Proposed Development 5**
- 4 Relevant Guidance 5**
 - 4.1 National Planning Policy Framework..... 5
 - 4.2 Planning Practice Guidance 6
 - 4.3 Institution of Lighting Professionals 6
 - 4.4 Lawn Tennis Association (LTA) Best Practice Advice 8
- 5 Methodology 8**
 - 5.1 Model and Assessment Approach..... 8
 - 5.2 Environmental Zone 9
 - 5.3 Lighting Requirements 9
 - 5.4 Sensitive Receptors 9
 - 5.5 Model Limitations..... 9
- 6 Baseline Assessment 10**
 - 6.1 Environment and Existing Light..... 10
 - 6.2 Sky Glow..... 11
- 7 Lighting Design 13**
 - 7.1 Equipment and Design Detail..... 13
 - 7.2 Maintenance Factor 14
 - 7.3 Wattage..... 14
- 8 Lighting Reality Model Results 14**
- 9 Impact Assessment..... 15**
- 10 Operational Control and Mitigation..... 17**

11 Designers Risk Assessment17

12 Conclusion and Summary 18

APPENDICES 19

Glossary of Terms 24

1 Introduction

- 1.1 Miller Goodall Ltd has been instructed to prepare an exterior lighting design and associated lighting impact assessment for three new padel courts at The New Croft, Chalkstone Way, Haverhill, CB9 0BW. The site lies within the administrative area of West Suffolk District Council (WSDC).
- 1.2 Lighting for each padel court is required. Best practice design and mitigation have been incorporated into the exterior lighting design. This includes the selection of appropriate luminaires and optics, heights and placement positions. Measures to reduce obtrusive light and pollution are inherent to the design, meeting the requirements of the Institution of Lighting Professionals (ILP) GNI^[1] and the Lawn Tennis Association's (LTA) best practice guide².
- 1.3 The padel courts are provided as an all-in-one package, comprising the structure and lighting. The manufacturer is based in Spain, and they source luminaires from FILUX³.
- 1.4 The manufacturer has provided a lighting design to show that the intended luminaire will meet the required lighting level for a single court. However, the design is not a comprehensive impact assessment; rather, it is a lux plot limited to a single padel court playing surface, demonstrating the feasibility of achieving the desired lighting standard using the supplied products.
- 1.5 The lighting design has, therefore, been modelled using the industry-adopted and widely used 2D lighting software Lighting Reality. The Reality Outdoor package has been used as it is suited for area design. Drawings, illuminance contour plots and the impact assessment support the design.
- 1.6 A lighting impact assessment has been undertaken to provide a baseline review and an assessment of the potential obtrusive lighting impacts associated with the development on nearby sensitive receptors. The assessment has been prepared in accordance with guidance issued by the ILP and LTA.

2 Site Description

- 2.1 The site is located in the footprint of The New Croft – Haverhill Community Sports Association sports complex, which lies at the northwestern edge of the Haverhill urban area. The padel courts will be located in the central-south area of the complex.

¹ Institution of Lighting Professionals, 2021. Guidance Note 01 The Reduction of Obtrusive Light.

² Lawn Tennis Association (undated). Padel Court Data Sheet

³ FILUX. Available at: <https://filux.com/en/>

- 2.2 The sports complex bounds all sides of the padel courts. To the north are Go Wild Axe Throwing cages, beyond which lie a lit football pitch, hockey pitch and tennis courts, and the Samuel Ward Academy. A car park and visitor centre lie to the east, with a lit sports pitch beyond. The 'Yoga Hive' clubhouse borders the site to the south, which extends to the same length as two of the three padel courts, providing an effective natural block to light spill.
- 2.3 Chalkstone Way is located beyond the clubhouse to the south and is bordered by trees on the north side and dwellings on the south side. These dwellings are approximately 60 m from the padel courts. An unlit green field training space lies to the west.
- 2.4 **Figure 1** shows an aerial night time image showing the context of the area. The site location is shown in **Appendix A**.

Figure 1: Aerial Photograph of the southern part of the Sports Complex, and Intended Padel Court Location



3 Proposed Development

- 3.1 The development comprises the construction of three padel courts. The structure includes a semi-translucent canopy over the roof and part-way down the sides. The premises will operate in accordance with the operational hours of the sports complex. Sports lighting is switched off from 22:00.

4 Relevant Guidance

4.1 National Planning Policy Framework

4.1.1 Paragraph 198 of the National Planning Policy Framework⁴ states:

“Planning policies and decisions should also ensure that new development is appropriate for its location taking into account the likely effects (including cumulative effects) of pollution on health, living conditions and the natural environment, as well as the potential sensitivity of the site or the wider area to impacts that could arise from the development. In doing so they should: [...] c) limit the impact of light pollution from artificial light on local amenity, intrinsically dark landscapes and nature conservation.”

4.2 Planning Practice Guidance

4.2.1 Planning Practice Guidance (PPG) includes guidance on light pollution⁵. The PPG discusses when and where lighting is needed and important matters to consider in the design, such as dark sky areas and avoiding light pollution. The guidance emphasises *‘it is important to get the right light, in the right place and for it to be used at the right time’*. The three-Rs phrase is often observed in the lighting industry as the basis of good design practices.

4.2.2 The PPG is organised by a series of questions and answers, in addition to open-ended questions that encourage the developer and lighting designer to contemplate the design and lighting needs. The PPG continues by outlining good practices such as limiting upward light spill and selecting appropriate luminaire for the task.

4.3 Institution of Lighting Professionals

Guidance Note 1, The Reduction of Obtrusive Light

4.3.1 The Institution of Lighting Professionals (ILP) GNI^[1] provides methodologies to reduce the adverse effects of artificial light. The document identifies best practice installation and designs to limit the environmental effects of poor lighting that may lead to adverse levels of light spill, sky glow and glare to surrounding sensitive uses.

4.3.2 Different environments may be more tolerant of light than others. The ILP has created a series of Environmental Zone (EZ) definitions that comprise limits for pre- and post-curfew⁶. The EZ and

⁴ Ministry of Housing, Communities & Local Government, 2024. National Planning Policy Framework.

⁵ Department for Levelling Up, Housing and Communities and Ministry of Housing, Communities & Local Government, 2019. Planning Practice Guidance, Light Pollution.

⁶ The guide does not define a specific curfew. 23:00 to 07:00 is often taken to be curfew, which corresponds to other planning and environmental disciplines such as acoustics, and sleeping patterns of humans. A stricter curfew may apply, such as dark sky.

illuminance (lux) levels for intrusion into windows (such as dwellings) are provided in **Table 1**.

Table 1: Environmental Zones

Environmental Zone & Definition	Light Intrusion (into windows) Ev (lux)	
	Pre-curfew	Post-curfew
E0: Dark sky parks, UNESCO Starlight Reserves	0	0
E1: Intrinsically dark landscapes. Examples: National Park, Areas of Outstanding Beauty	2	(1*)
E2: Low district brightness. Examples: rural, small village, relatively dark urban location	5	1
E3: Medium district brightness. Examples: small town centres or urban locations	10	2
E4: High district brightness areas. Examples: town/city centres with high night-time activity levels	25	5

Ev: Vertical illuminance

*Permitted only from public road light installation

The EZ table also includes levels for sky glow, luminaire intensity (luminance) and building luminance. Sky glow, luminance and glare can be controlled through the luminaire selection and design.

Example levels of lux include: daytime (50,000), overcast sky (5,000), office & task (500), street lighting (5 to 20), full moon (0.25 to 1)

Professional Lighting Guide 4, Guidance on Undertaking Environmental Lighting Impact Assessments

4.3.3 ILP Professional Lighting Guide (PLG) 04 ^[7] is the industry standard document outlining the approach, content recommendations and general advice and mitigation for completing lighting impact assessments in the UK. The aim of this guidance is to outline best practice measures in lighting design and provide practical guidance on the production and assessment of lighting impacts within new developments.

4.3.4 A key requirement of the guidance is that obtrusive light impact assessment must be modelled using a maintenance factor of 1.0 in the design and results. This ensures the scheme is assessed to the full lumen output at installation, representing worst-case exposure to sensitive receptors when lumen output is at the maximum at installation, rather than the lumen output representing the

⁷ Institution of Lighting Professionals, 2013. Professional Lighting Guide 4, Guidance on Undertaking Environmental Lighting Impact Assessments.

design level after degradation has occurred overtime.

4.4 Lawn Tennis Association (LTA) Best Practice Advice

4.4.1 The LTA guidance² contains best practice advice on all matters of design, installation and operation of padel tennis courts, including lighting. The guidance states: “While the minimum levels are stated a 10% over performance should be taken into consideration when undertaking the initial design i.e. (0.9 maintenance factor)”. Details include ideal lighting layouts and lighting standards.

Table 2 shows the recommended lighting levels for outdoor courts.

4.4.2 Similar lighting standards also exist in BS 12193:2018 Light and lighting: Sports lighting. This British Standard is now several years old and is listed as ‘under review’ on the British Standards Institution (BSI) website. The only difference for recreational use is that BS 12193:2018 lists 0.7 uniformity whilst the LTA guidance uses 0.5. The LTA guidance is used in this assessment.

Table 2: Lighting Levels

Task Area	Lighting Standard	
	Average Horizontal	Uniformity
	Lux	
National and International Competition	500	0.7 (70%)
Regional competition/recreational use	300	0.5 (50%)

5 Methodology

5.1 Model and Assessment Approach

5.1.1 The lighting design has been modelled using Lighting Reality and its software package, Reality Outdoor (v2.3.1). The design includes calculated maintenance factors to ensure that the correct lighting levels are maintained for the installation's lifespan

5.1.2 An impact assessment has been completed by applying a 1.0 maintenance factor, per the requirements of the ILP PLG4 Guidance⁷. The potential impact on surrounding sensitive receptors has been assessed by preparing a series of horizontal and vertical illuminance plots. The assessment includes lux predictions at the ground-floor (1.5 m window height) and the first-floor (4 m window height) windows.

5.2 Environmental Zone

5.2.1 The site is located in the urban area and is surrounded by established and extensive sports lighting. The site is considered to reside within EZ E3 *medium district brightness, Examples: small town centres or urban locations.*

5.3 Lighting Requirements

5.3.1 Lighting is required for the padel courts. **Table 3** shows the lighting standards applied.

Table 3: Relevant Lighting Requirements for this Assessment, LTA Padel Court

Type of Area, task or activity	Maintained Illuminance (\bar{E}_m, lx)	Min Illuminance Uniformity (U_o)
Recreational use Padel Courts (per court)	300	0.5 (50%)

5.4 Sensitive Receptors

5.4.1 The site lies within the footprint of the sports complex, therefore, there are no sensitive receptors in close proximity to the development. The closest dwellings are located on the south side of Chalkstone Way, approximately 60 m to the south of the site. There are no ecological sensitive receptors identified that require further assessment.

5.4.2 **Table 3** shows the locations of sensitive receptors considered in this assessment, selected as worst-case positions nearest to the lit areas. The model calculates vertical lux via a 3D line source, with the height set from 1.5 to 4 m to represent the floors of the dwelling. **Appendix A** shows the ESR grid positions.

Table 4: Sensitive Receptors

Receptor	Location and Description	Coordinates*		Receptor Type
		X	Y	
ESR 1	Chalkstone Way, Dwellings	567729	245953	Human
ESR 2	Environment, Sky Glow, Glare	N/A		Environment

*grid reference represents a central location along the vertical grid line

5.5 Model Limitations

- 5.5.1 The light model does not take into account intervening vegetation, retaining walls, buildings or obstructions. Obstruction to light spill is, therefore, not accounted for in model outputs.
- 5.5.2 The structure will be fitted with a semi-translucent canopy, which covers the roof and extends partly down the sides of the structure.
- 5.5.3 **Figure 2** shows two example photographs of the canopy.

Figure 2: Photograph of Example Canopy



- 5.5.4 As shown, the material is not fully opaque, however, it does still act as an effective blockage to light spill. The material obscures the luminaire, effectively eliminating the viewing angle that would cause glare issues to external receptors.
- 5.5.5 The percentage reduction to light spill cannot be quantified, and Lighting Reality is unable to model this situation effectively. The model results present outputs of an open-air padel court, however, a qualitative assessment of the canopy should be considered as part of the overall significance conclusion.

6 Baseline Assessment

6.1 Environment and Existing Light

- 6.1.1 The site is surrounded by an extensively lit sports complex, comprising fully lit sports pitches that far exceed the size of the padel courts footprint and column heights. The site will sit within the context of the sports complex and also operate within the same operating hours.

- 6.1.2 **Figure 1** shows an aerial view looking eastwards over the surrounding area. Several sports pitches in the sports complex are lit, as well as ancillary uses, such as the welcome centre and parking areas. Outside of the viewpoint lies several other lit pitches to the north. Consequently, the baseline environment in the immediate area around the site includes extensive lighting.
- 6.1.3 The sports complex includes floodlighting and sports requirement lighting provisions. These include floodlights installed on masts around 15 m high. These are positioned around the perimeter of all lit pitches. Street View© imagery indicates existing lighting meets good practice, as floodlights are flat (i.e. no tilt) and many incorporate louvres to minimise light pollution. The site shows high standards of installation and operation, consistent with ILP obtrusive best practice lighting guidelines.
- 6.1.4 Street lighting is present along Chalkstone Way and on the residential side street branching off Chalkstone Way. The wider urban area of Haverhill borders the sports complex to the east, south and west. The local area within 500 m of the site is mostly residential use.

6.2 Sky Glow

- 6.2.1 The site is at the urban edge of several urban settlements, with major urban conurbations in the regional area. The Light Pollution Map⁸ provides Geographic Information System (GIS) sky brightness values (sky quality meters mag/arcsec²), with comparisons of the Bortle Scale. The Bortle Scale is a 9-category classification of sky quality, based on the numerical values of sky brightness, shown in **Figure 3**.

⁸ Light Pollution Map. Available at: <https://www.lightpollutionmap.info>

Figure 3: Sky Brightness Classification⁹

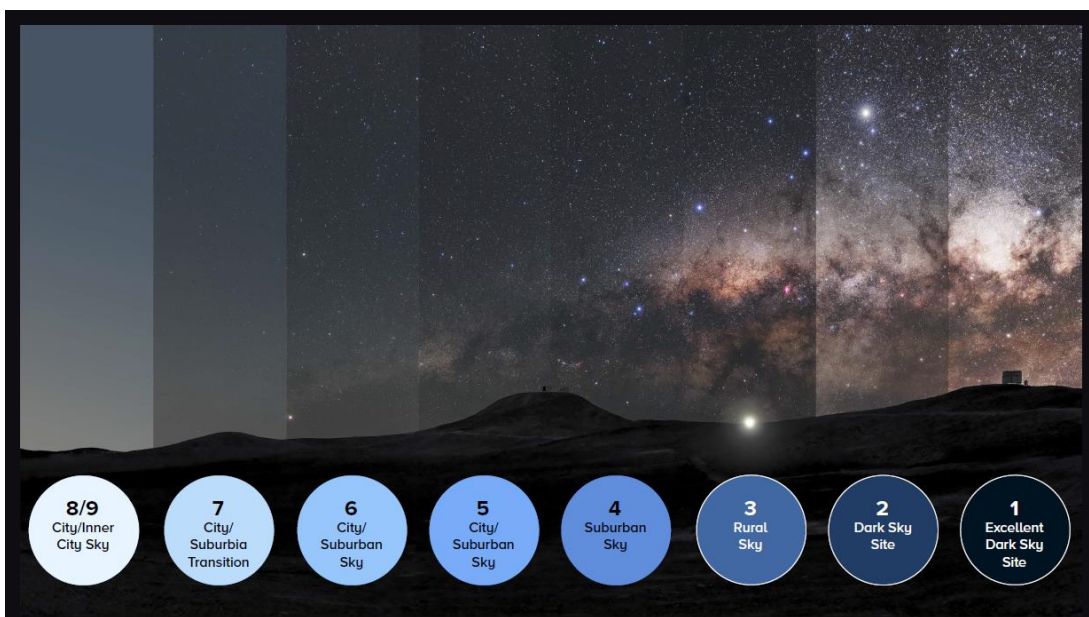

6.2.2 **Figure 4** shows the site's estimated sky quality index, 'Bortle Zone 5', corresponding to a 'suburban sky' rating.

Figure 4: Sky Brightness of the Proposed Development Site

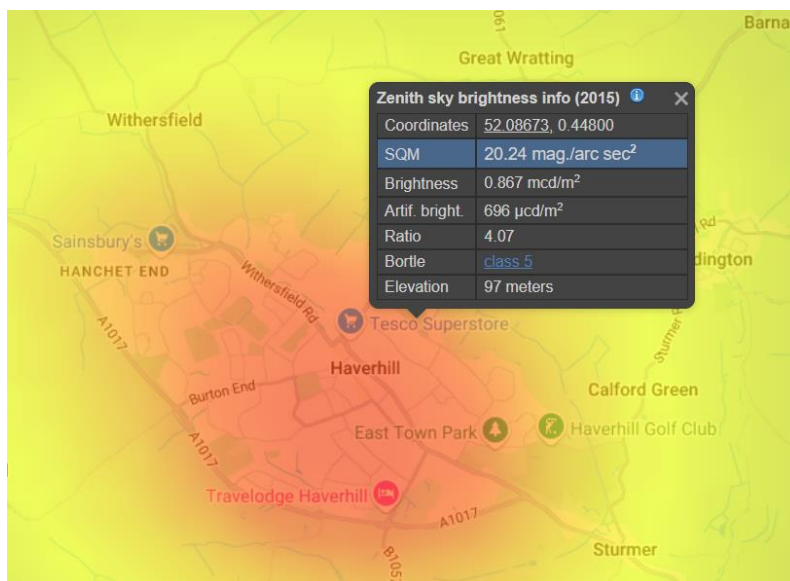

⁹ Image credit: Welsh Government, 2025. Good Practice Guidance: Planning for the Conservation and Enhancement of Dark Skies in Wales

7 Lighting Design

7.1 Equipment and Design Detail

Proposed Lighting Equipment

- 7.1.1 There are four 6 m columns positioned around each padel court, with each column holding two floodlights. Therefore, there are eight floodlights per court, with 24 floodlights total at the three courts. This setup meets LTA best practice². Each column is 4 m inward from the edge.
- 7.1.2 Each court is lit to the required lighting standard. This allows individual courts to be switched on or off, corresponding to customer usage levels. The three courts are positioned side-by-side, therefore, the centre courts will receive light spill from the adjacent courts and may appear to be overlit. However, it is necessary to ensure each court can meet the required lighting standard in isolation if other courts are switched off.
- 7.1.3 The floodlight luminaire is listed as FT-21200 (F-2144). The product specification sheet is provided in **Appendix B**. The specifications include: 200-watt luminaire, 4000 Kelvin colour temperature, ingress protection IP65 and colour rendering index >80, symmetrical optic.
- 7.1.4 The layout includes benches along the east side of the courts at the edge of the structure. Light spill from the padel courts will provide more than sufficient lighting for this purpose. Isolated lighting in the bench area is not deemed to be required.
- 7.1.5 **Table 5** details the lighting design equipment inventory.

Table 5: Equipment Inventory

Product	Type & Optic	Lumen Output (flux klm)	Wattage (w)	Quantity	Image
FILUX FT-21200	Post-mounted Floodlight, 110° symmetrical	26.00	200	24	

7.2 Maintenance Factor

- 7.2.1 During the lifespan of a luminaire, the lumen output naturally degrades, becomes obscured by dirt, and suffers light loss. This effect is accounted for in the design by applying a maintenance factor (MF) which models the end-of-life lighting level to account for this degradation. An adverse effect of this procedure is that the calculated MF models the lighting levels towards the end of the product lifespan and the post-degradation lumen output. Consequently, at day one of installation, the lumen output will be higher, as no degradation of the product has yet to occur.
- 7.2.2 The padel court manufacturer advises that the FILUX luminaire's specific maintenance factor is 0.9. Therefore, the LTA's requirement to include a 10% overlighting inclusion (i.e. 0.9 maintenance factor) is met.
- 7.2.3 For lighting impact assessment, the ILP⁷ recommends that MF 1.0 is set to assess the potential impact on surrounding sensitive receptors, ensuring the light spill is assessed at worst-case conditions, representing day one installation lighting levels.
- 7.2.4 The lighting design is initially prepared using a calculated MF and then revised to MF 1.0 for the impact assessment.

7.3 Wattage

- 7.3.1 The total power requirement of the design (**Table 5**) is 4800 watts (4.8 kW). This assumes full operation at installation. No revisions are made for switch-off or operating times.

8 Lighting Reality Model Results

- 8.1 A lighting model was created for the development to assess the products to be used. The model includes lighting on all three courts, providing a cumulative impact assessment and lux predictions at surrounding human sensitive receptors from the lit development.
- 8.2 The Reality Outdoor output report provides equipment selections, optic images, positions and results for each calculation grid and area of use/task, shown in **Appendix C**. The Reality Outdoor appendix lists the results for MF1.0 for the purpose of the impact assessment. An AutoCAD horizontal lux contour plot and details of the design is provided in **Appendix D**.
- 8.3 **Table 6** provides a summary of the design levels achieved. The court luminaire positions have been replicated in the model and the luminaire photometry file provided by the Supplier has been used.

- 8.4 The results show the lighting standard achieved for a single in-isolation padel court, demonstrating it meets the required standard. Each padel court is lit to this individual standard, as it is necessary for each padel court to operate independently to reflect customer requirements (i.e. booking and usage levels).
- 8.5 When all three courts are running, the light spill from neighbouring courts interact, creating higher lighting levels across the padel court area. This is a common issue as developments of this nature require per court lighting and are usually constructed side-by-side with clear panelling between each court. This does not impact the customer's experience, nor does it lead to a significant change in the outward light spill as each court is still lit to its own standard (i.e. similar outward light profile).
- 8.6 The cumulative lux when all three courts are lit is provided in **Table 6** (maintenance factor 1). In summary, each padel court receives approximately 50% contribution from its neighbouring court. Dimming the two outer courts to 80% and the central court to 50% will reduce lighting levels to approximately 365 lux on each court. Consequently, when all three courts are operating and a dimming profile is used, the lighting standard is still achieved and the operator can reduce their energy and running costs by approximately one third.

Table 6: Lighting Model Design Results

Task	Targets	Design/Result Achieved
Single Court, maintenance factor 0.9		
Padel Court (recreational use)	Average Horizontal Lux: 300 Uniformity: 0.50 (50%)	Average Horizontal Lux: 345 Uniformity: 0.67 (67%)
Cumulative - All three courts lit, maintenance factor 1		
Court 1 (Right)	Average Horizontal Lux: 300 Uniformity: 0.50 (50%)	Average Horizontal Lux: 494 Uniformity: 0.65 (65%)
Court 2 (Central)	Average Horizontal Lux: 300 Uniformity: 0.50 (50%)	Average Horizontal Lux: 600 Uniformity: 0.64 (64%)
Court 3 (Left)	Average Horizontal Lux: 300 Uniformity: 0.50 (50%)	Average Horizontal Lux: 495 Uniformity: 0.63 (63%)

9 Impact Assessment

- 9.1 The results presented are for a typical switched-on operation. The premises will operate until 22:00, after which all lighting will be switched off.

9.2 As discussed, the Applicant intends to install a semi-translucent canopy over the roof and part of the sidewalls as an additional environmental mitigation action. Lighting Reality is unable to quantitatively model the canopy, but reductions in outward light spill are expected. A qualitative assessment of the canopy should be considered as part of the overall significance conclusion.

Horizontal Lux

9.3 The horizontal average lux contour plot is shown in **Appendix D**. The distance from the padel court boundary to the point when less than 1 lux is met is approximately 28 m both on the long and short edge from the court.

9.4 The potential lux impact is, therefore, negligible and not significant.

Vertical Lux

9.5 The assessment has predicted vertical lux at one existing sensitive receptor. The results of the assessment are shown in **Table 7**. There is no operational lighting during the post-curfew hours.

Table 7: Vertical Lux Results at ESR Positions, Proposed Lighting

Receptor	Pre-Curfew Limit (Lux)	ESR Vertical Lux		Significance
		1.5 m Height	4 m Height	
ESR 1: Chalkstone Way Dwellings	10	0.31	0.20	No Exceedance

9.6 The potential lux impact is negligible and not significant. As noted, there is no operation during the post-curfew period.

Sky Glow

9.7 Proposed luminaires will be installed with no tilt angle. The canopy will obstruct upward light contributions.

9.8 The effects of skyglow are concluded to be not significant.

Glare

9.9 The semi-translucent canopy will act as a diffuser regarding viewpoints towards the LED plate of the luminaire. The obstruction will resolve the peak light intensity when viewing the luminaire from an outside position. The Yoga Hive building and trees also obstruct views from the south towards the developments.

9.10 The padel court supplier carries out glare calculations to ensure the chosen luminaire will not cause glare issues to padel court users.

9.11 The effects of glare on the surrounding sensitive receptors can be concluded as not significant.

10 Operational Control and Mitigation

10.1 The padel court will operate during the evening, with full closure from 22:00. After this time, there is full switch off all lighting. These operating hours follow those already established by The New Croft – Haverhill Community Sports Association.

10.2 When all three courts are operating, light spill from neighbouring padel courts occurs, leading to higher lighting levels than needed with reference to the LTA standard. By operating a dimming profile, the operator can reduce their energy and running costs. A dimming profile, tested via a modelling scenario, is presented in paragraph 8.5.

11 Designers Risk Assessment

11.1 This lighting design has been prepared for a planning application. Specifics surrounding installation, connection and maintenance have yet to be defined.

11.2 In accordance with the Construction Design and Management Regulations 2015, the following assumptions and considerations should be noted. The Institution of Lighting Professionals has also published Guidance Note 4 (2016) '*CDM 2015 Overview*' to aid this process.

- The design and output calculations are based on the products used, presented in **Appendix C**. Any revisions to this may alter the final lighting profile and should be accounted for in a redesign.
- The column positions and luminaire photometry files were provided by the manufacturer and supplier of the all-in-one padel court equipment. Miller Goodall Ltd has carried out a sense check of the data and files and found them to be suitable. Any specific queries to equipment or placement should be directed to the supplier.
- The colour temperature the Supplier is providing is unknown. Miller Goodall Ltd has suggested a 4000 Kelvin colour temperature is installed, as this temperature contains less blue wave length content.
- The design does not account for installation or electrical installation considerations, site conditions or provide an installation or maintenance risk assessment. Future maintenance needs have been accounted for in the design.

- The contractor shall liaise with the District Network Operator (DNO) (UK Power Networks) and/or appointed electrical engineer to organise or action electrical amendments and connections. Competent person(s) certified to handle electrical installations shall install the equipment.
- The contractor shall identify any overhead or underground obstacles or infrastructure that may pose risk or harm associated with the installation of the design before the physical installation (i.e. utility drawings). The contractor shall consult with relevant Bodies, as necessary upon identifying any issues.
- The design assumes there are no obstacles. Obstacles identified in the site layout plan have been accounted for in the design (for example, structures and vegetation).
- Future maintenance should be carried out according to appropriate standards, health & safety procedures and the manufacturer's requirements/standards.
- The installation and column planting shall be carried out according to relevant British Standard Institution guidance relevant to the activity and/or required action.

12 Conclusion and Summary

- 12.1 An exterior lighting design and impact assessment have been completed for the proposed padel court development at Haverhill Padel Courts, The New Croft, Chalkstone Way, Haverhill, CB9 0BW.
- 12.2 The lighting design meets the lighting standard requirements for recreational padel court use set by the Lawn Tennis Association. Details of the padel court setup and luminaire details have been provided by the supplier and modelled.
- 12.3 The assessment concludes that the potential illuminance vertical intrusion impact on surrounding human sensitive receptors is not significant and meets the requirements of the Institution of Lighting Professionals guidance.
- 12.4 The assessment demonstrates an appropriate lighting design for the intended use. It indicates that there will be no impact on surrounding sensitive receptors and that the adverse effects to the surrounding environment are limited due to the inclusion of embedded mitigation and operational controls. All lighting will be switched off from 22:00.
- 12.5 There is no reason for the application to be refused on the grounds of lighting.

APPENDICES

Appendix A – Site Location and Receptors

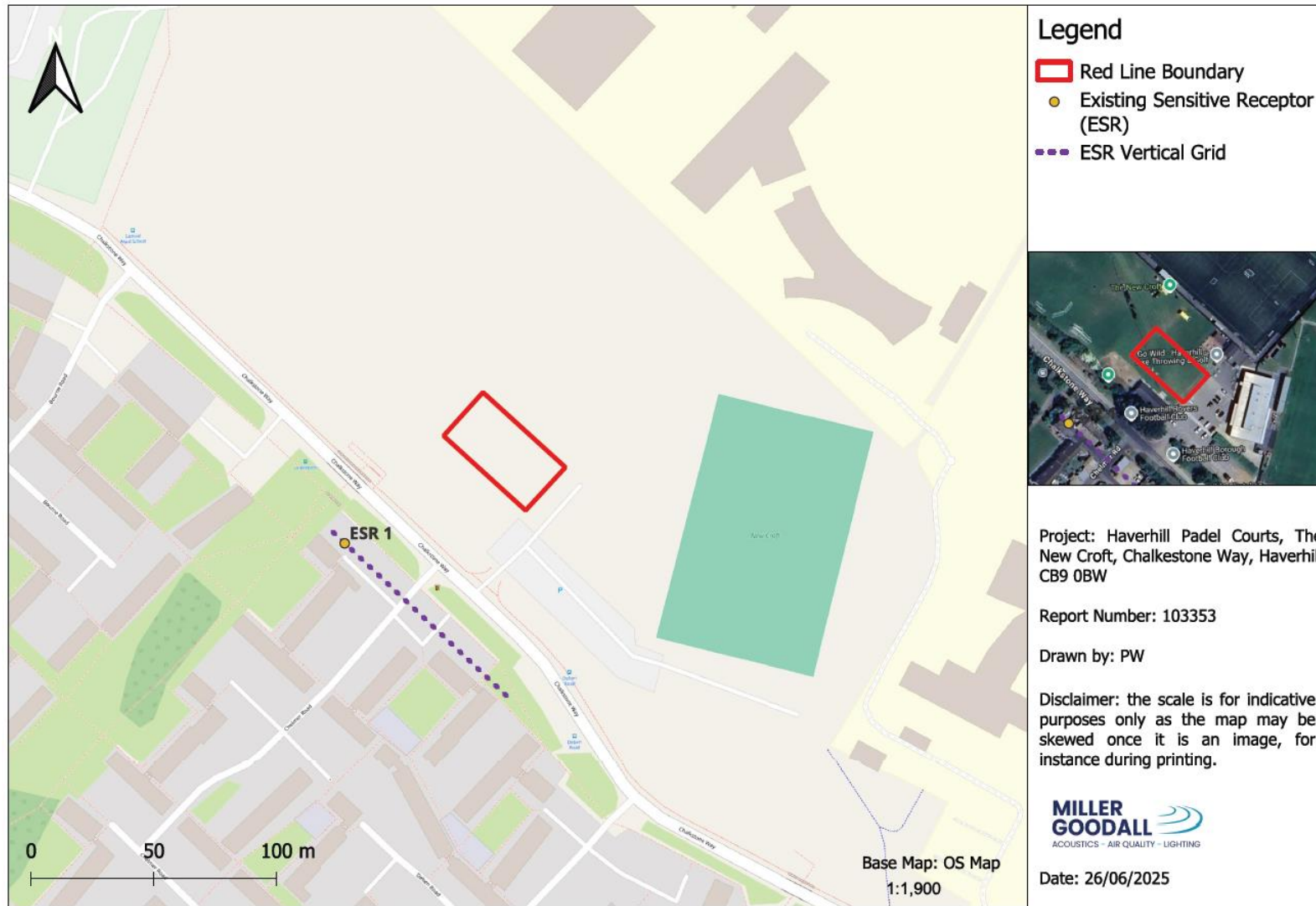

Appendix B – FILUX luminaire specification PDF

FICHA TÉCNICA DATA SHEET FICHA TÉCNICA



LED FLOODLIGHTS 200W. Proyector LED | LED floodlight | Projektor LED

Información general

Es el sustituto perfecto para los focos halógenos de exterior. Se puede inclinar para dirigir la luz en función de las necesidades del momento. La luz que emite es de alta calidad como indica su CRI. El ángulo de apertura resulta muy adecuado como elemento de iluminación general.

General information

The perfect substitute for outdoor halogen spotlights. It can be tilted to direct the light according to the needs of the moment. The light it emits is of high quality as its CRI indicates. The opening angle is very suitable as a general lighting element.

Informações gerais

É o substituto perfeito para holofotes de halogênio ao ar livre. Pode ser inclinado para direcionar a luz, dependendo da necessidades do momento. A luz que emite é alta qualidade como indicado pelo seu CRI. Os resultados do ângulo de abertura muito adequado como elemento de iluminação geral.



30.000H



5 YEAR WARRANTY



IP65



130LM/W



CRI >80



110°



4KV



PF >0,95



+45° | -20°

Dimensiones | Dimensions | Dimensões

110°

Ángulo Apertura
Beam Angle
Ângulo De Abertura

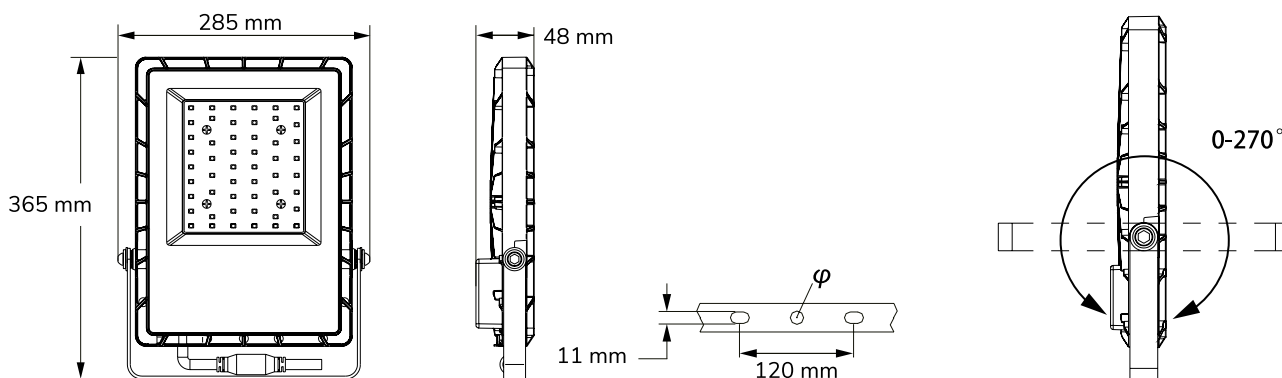

Fotometría | Photometry | Fotometria

Model	Sku	W	C.Temp	Lumens	Power
FT-21200	F2137	200	3.000K	22.000	220-240V, 50-60HZ
	F2138		4.000K	24.000	
	F2139		5.700K	24.000	

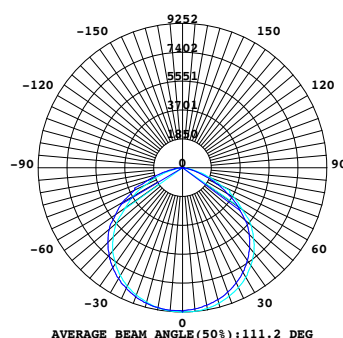

Appendix C – Lighting Reality: Reality Outdoor, Design Output

DATE: 27 June 2025
DESIGNER: Philip Walton
PROJECT No: 103353
PROJECT NAME: Haverhill Padel Courts



Design prepared using AutoCAD File "Haverhill Padel Courts_Planning Application"

Design Standard: Lawn Tennis Association
Per Court
Horizontal Average Lux (court): 300 lux
Uniformity: 0.5 (50%)

Exterior Lighting Design

Layout Report

General Data

Dimensions in Metres Angles in Degrees

Calculation Grids

ID	Grid Name	X	Y	X' Length	Y' Length	X' Spacing	Y' Spacing
1	Light Spill	1975889.01	330265.39	186.25	177.07	1.49	1.49
2	Court #1	1975981.15	330357.79	10.28	20.32	1.47	1.45
3	Court #2	1975971.71	330366.49	10.43	20.35	1.49	1.45
4	Court #3	1975962.60	330374.76	10.25	20.39	1.46	1.46
5	Clakstone Way Dwellings	1975913.83	330335.81	97.72	3.00	1.48	0.75

Luminaires

Luminaire A Data

Supplier	
Type	
Lamp(s)	F-200W
Lamp Flux (klm)	25.99
File Name	Filux F-21200 - F-2144 - 200W_ESNA2002.I ES
Maintenance Factor	1.00
Imax70,80,90(cd/klm)	97.5, 27.3, 2.1
No. in Project	24

Layout

ID	Type	X	Y	Height	Angle	Tilt	Cant	Out-reach	Target X	Target Y	Target Z
1	A	1975999.20	330362.52	6.00	139.00	0.00	0.00	0.20			
2	A	1975999.70	330363.14	6.00	139.00	0.00	0.00	0.20			
3	A	1975991.07	330353.68	6.00	139.00	0.00	0.00	0.20			
4	A	1975991.63	330354.26	6.00	139.00	0.00	0.00	0.20			
5	A	1975984.26	330361.05	6.00	319.00	0.00	0.00	0.20			
6	A	1975983.72	330360.46	6.00	319.00	0.00	0.00	0.20			
7	A	1975992.39	330369.88	6.00	319.00	0.00	0.00	0.20			
8	A	1975991.84	330369.29	6.00	319.00	0.00	0.00	0.20			
9	A	1975990.52	330371.62	6.00	139.00	0.00	0.00	0.20			
10	A	1975989.97	330371.02	6.00	139.00	0.00	0.00	0.20			
11	A	1975981.83	330362.19	6.00	139.00	0.00	0.00	0.20			
12	A	1975982.38	330362.78	6.00	139.00	0.00	0.00	0.20			
13	A	1975972.59	330370.70	6.00	139.00	0.00	0.00	0.20			
14	A	1975973.14	330371.29	6.00	139.00	0.00	0.00	0.20			
15	A	1975980.72	330379.53	6.00	139.00	0.00	0.00	0.20			
16	A	1975981.27	330380.11	6.00	139.00	0.00	0.00	0.20			

Layout Continued

ID	Type	X	Y	Height	Angle	Tilt	Cant	Out-reach	Target X	Target Y	Target Z
17	A	1975982.61	330377.79	6.00	319.00	0.00	0.00	0.20			
18	A	1975983.15	330378.39	6.00	319.00	0.00	0.00	0.20			
19	A	1975974.48	330368.97	6.00	319.00	0.00	0.00	0.20			
20	A	1975975.02	330369.56	6.00	319.00	0.00	0.00	0.20			
21	A	1975973.92	330386.89	6.00	319.00	0.00	0.00	0.20			
22	A	1975973.37	330386.30	6.00	319.00	0.00	0.00	0.20			
23	A	1975965.24	330377.47	6.00	319.00	0.00	0.00	0.20			
24	A	1975965.78	330378.05	6.00	319.00	0.00	0.00	0.20			

Polar Diagram

Luminaire A

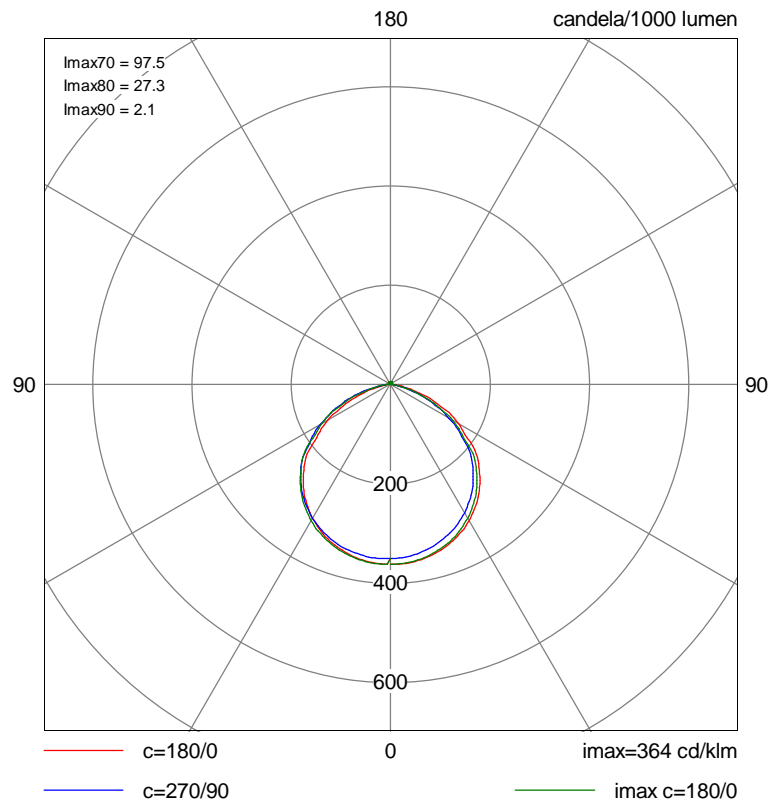

Luminaire Classification System (LCS) Graph

Luminaire A

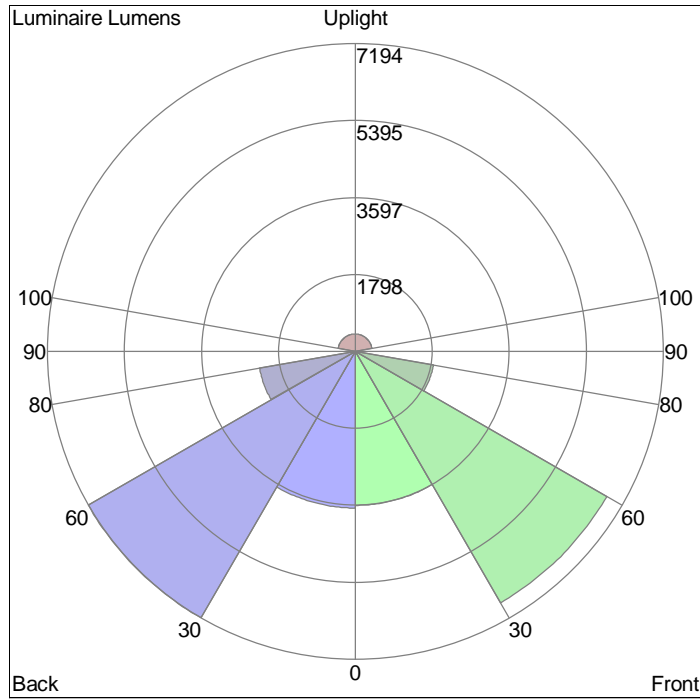

LCS	Lumens	%Lamp	%Lum
FL	3603.3	13.9	13.9
FM	6786.3	26.1	26.1
FH	1858.6	7.2	7.2
FVH	62.6	0.2	0.2
BL	3665.2	14.1	14.1
BM	7193.5	27.7	27.7
BH	2263.7	8.7	8.7
BVH	105.9	0.4	0.4
UL	52.3	0.2	0.2
UH	398.7	1.5	1.5
Total	25988.7	100.0	100.0

BUG rating=B5-U3-G2

Horizontal Illuminance (lux)

Light Spill - maintenance factor 1

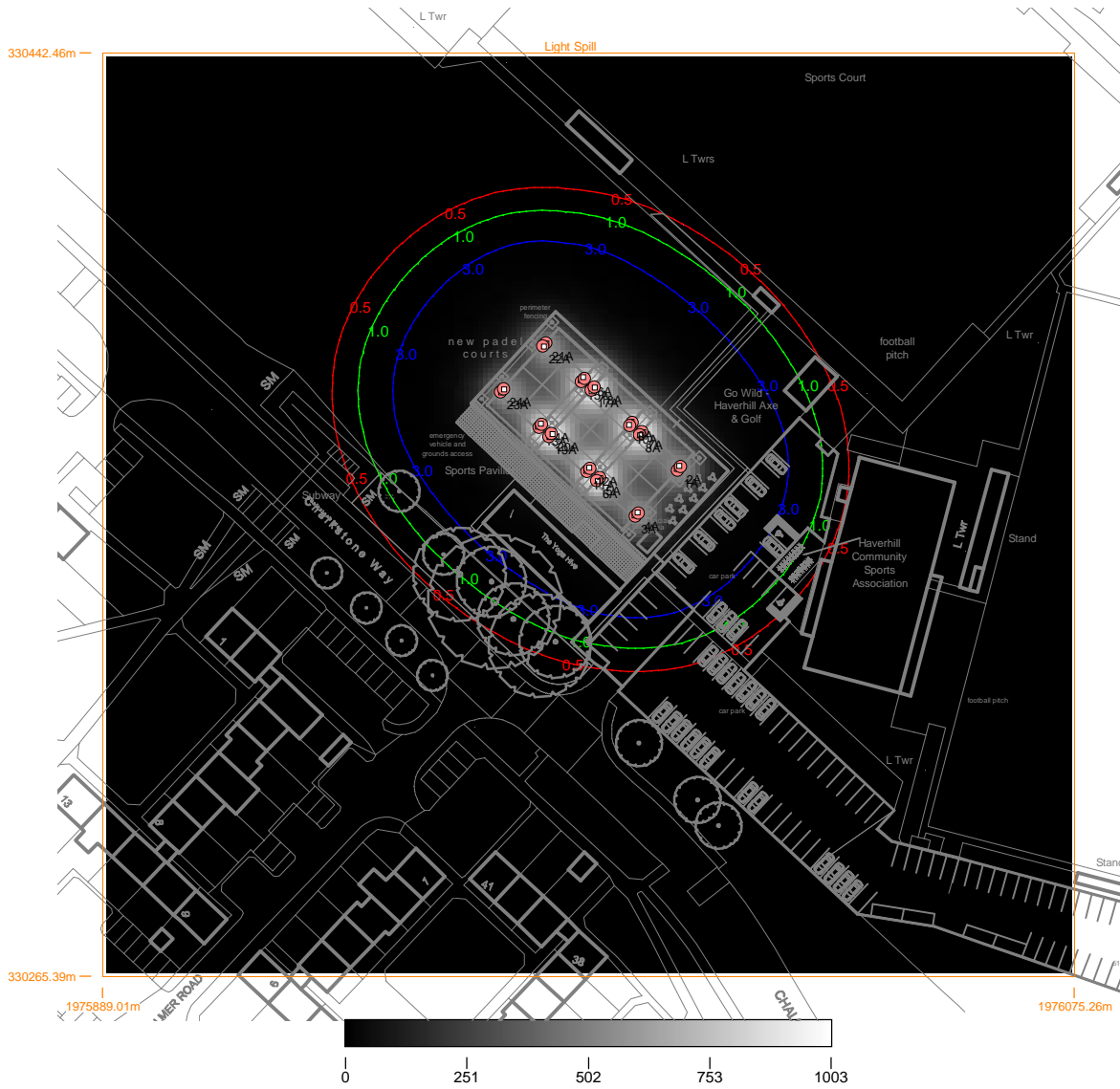

Horizontal Illuminance (lux)

Court #1

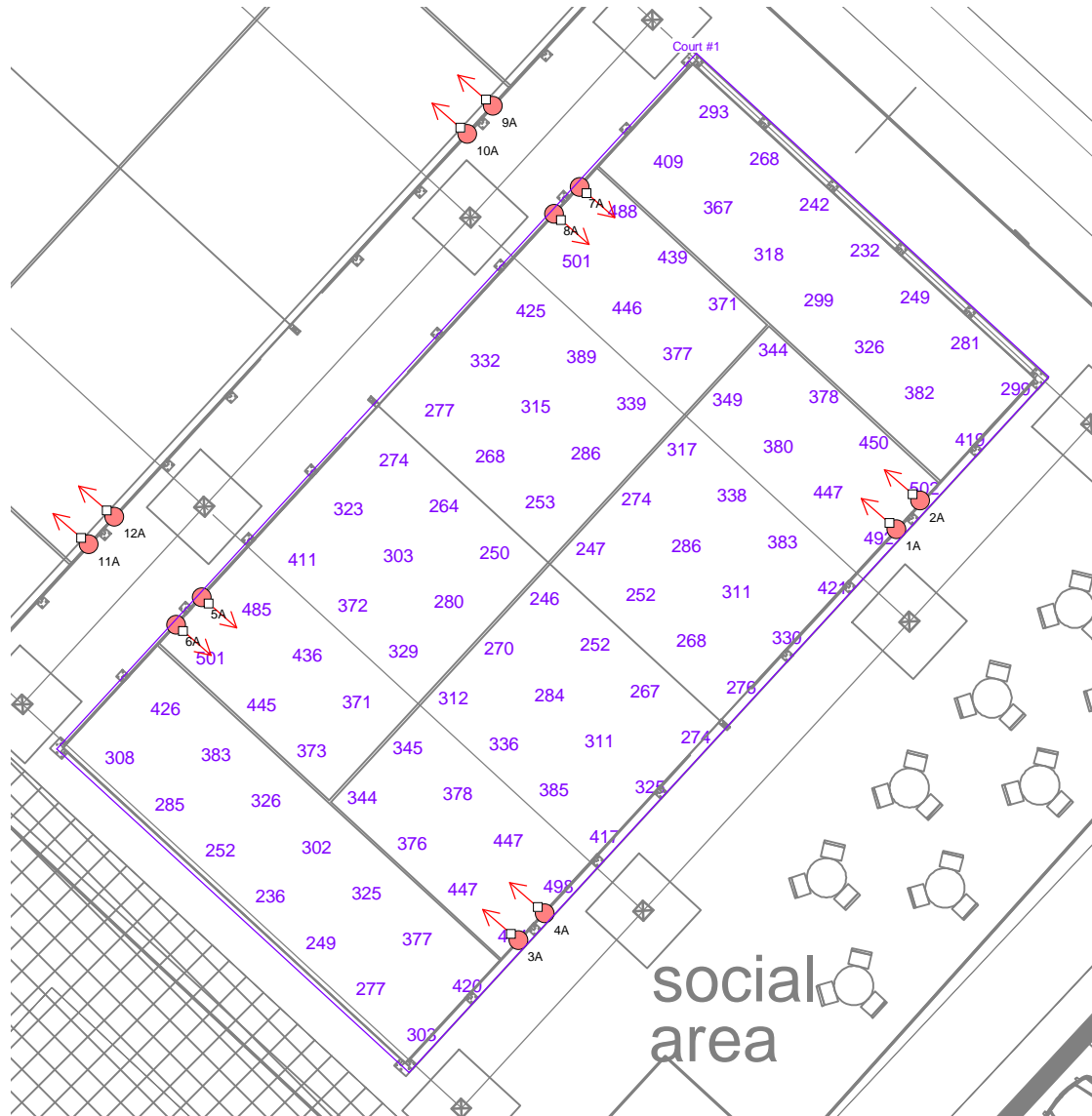

Results - Single Court In-isolation (Maintenance Factor 0.9)

Eav	345.22
Emin	232.21
Emax	501.91
Emin/Emax	0.46
Emin/Eav	0.67

Horizontal Illuminance (lux)

Court #1

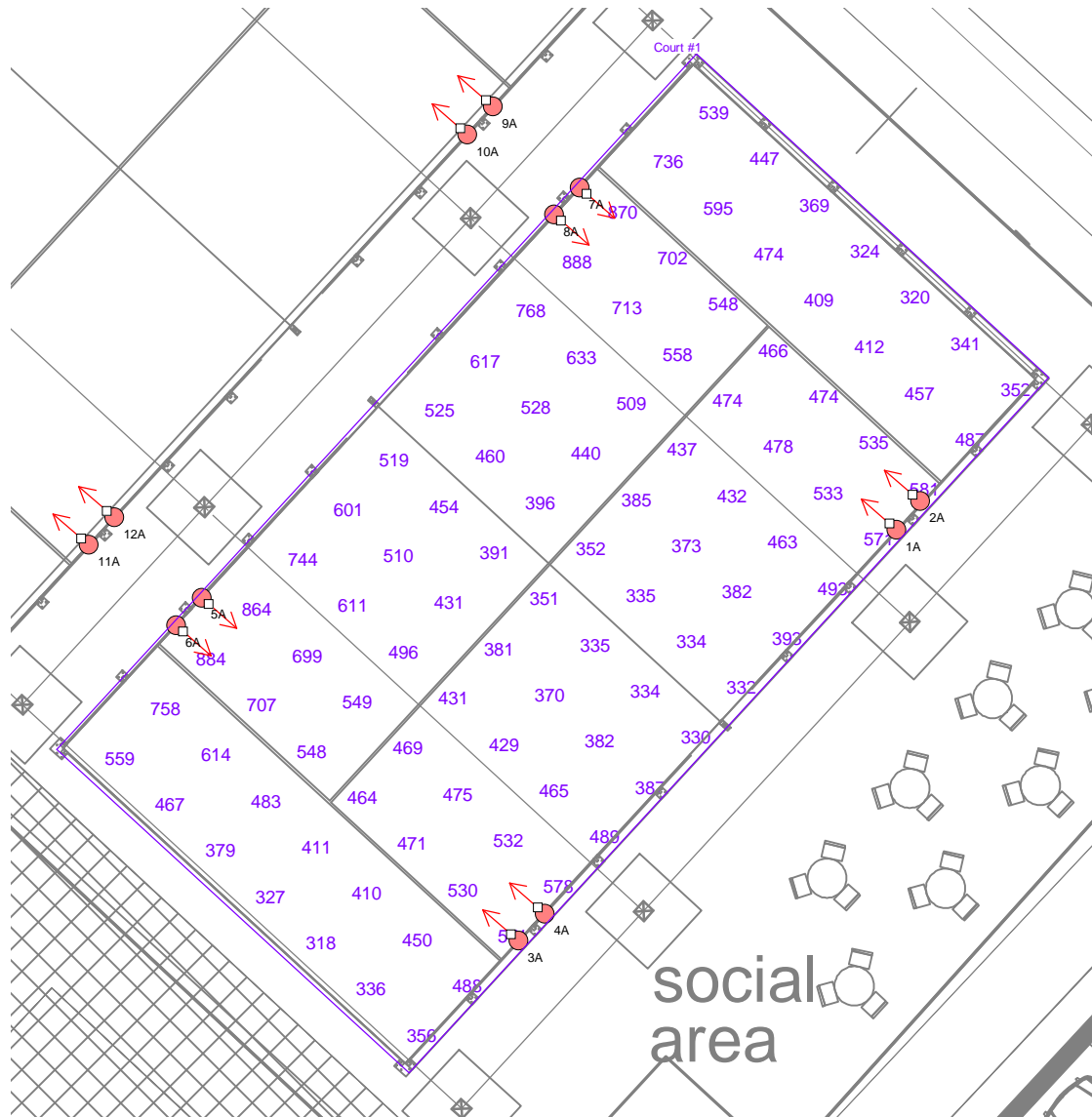

Results - cumulative all three courts lit, Maintenance factor 1

Eav	493.67
Emin	318.48
E _{max}	887.50
E _{min} /E _{max}	0.36
E _{min} /E _{av}	0.65

Horizontal Illuminance (lux)

Court #2

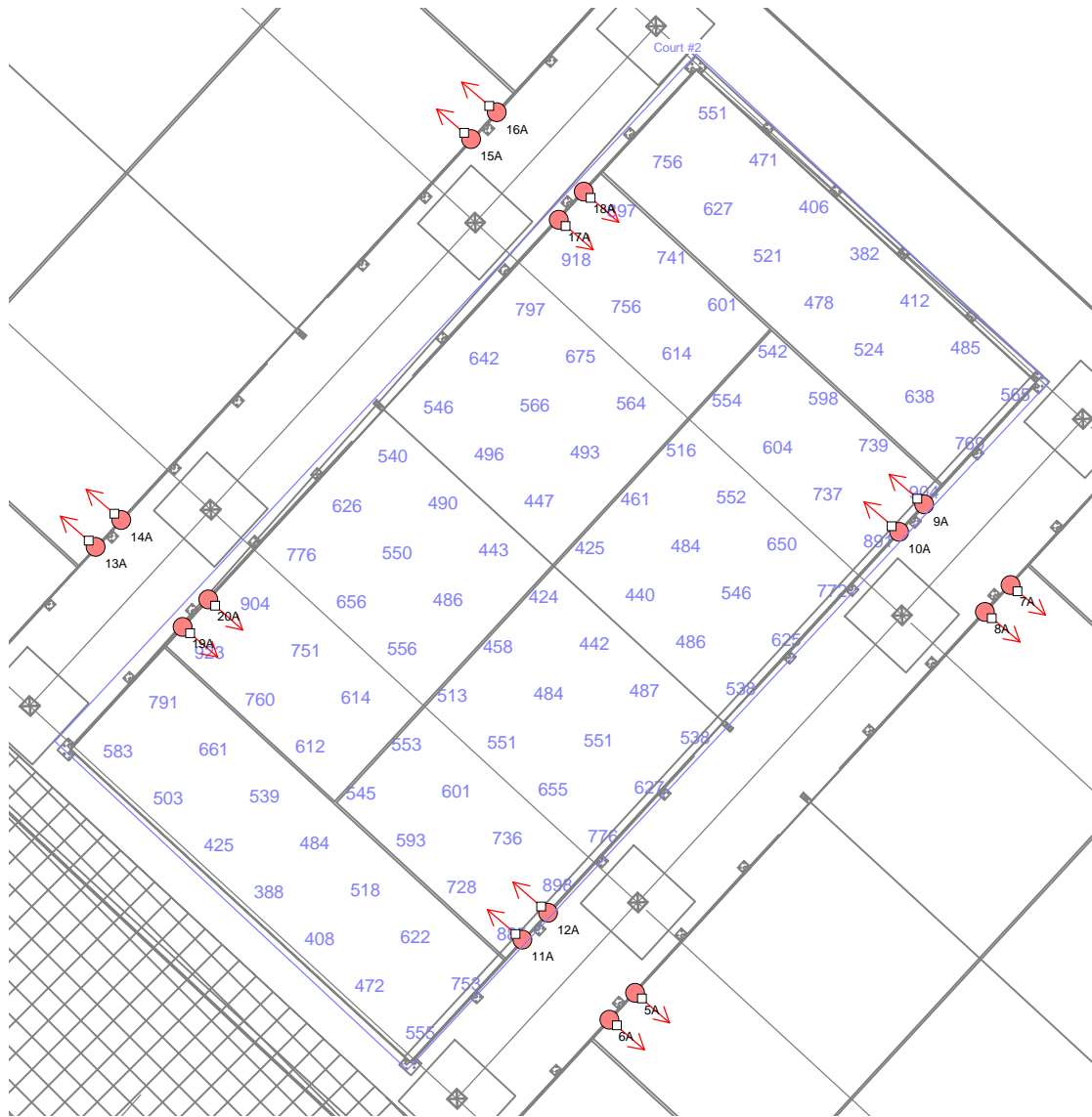

Results - cumulative all three courts lit, Maintenance factor 1

Eav	600.39
Emin	381.60
Emax	922.75
Emin/Emax	0.41
Emin/Eav	0.64

Horizontal Illuminance (lux)

Court #3

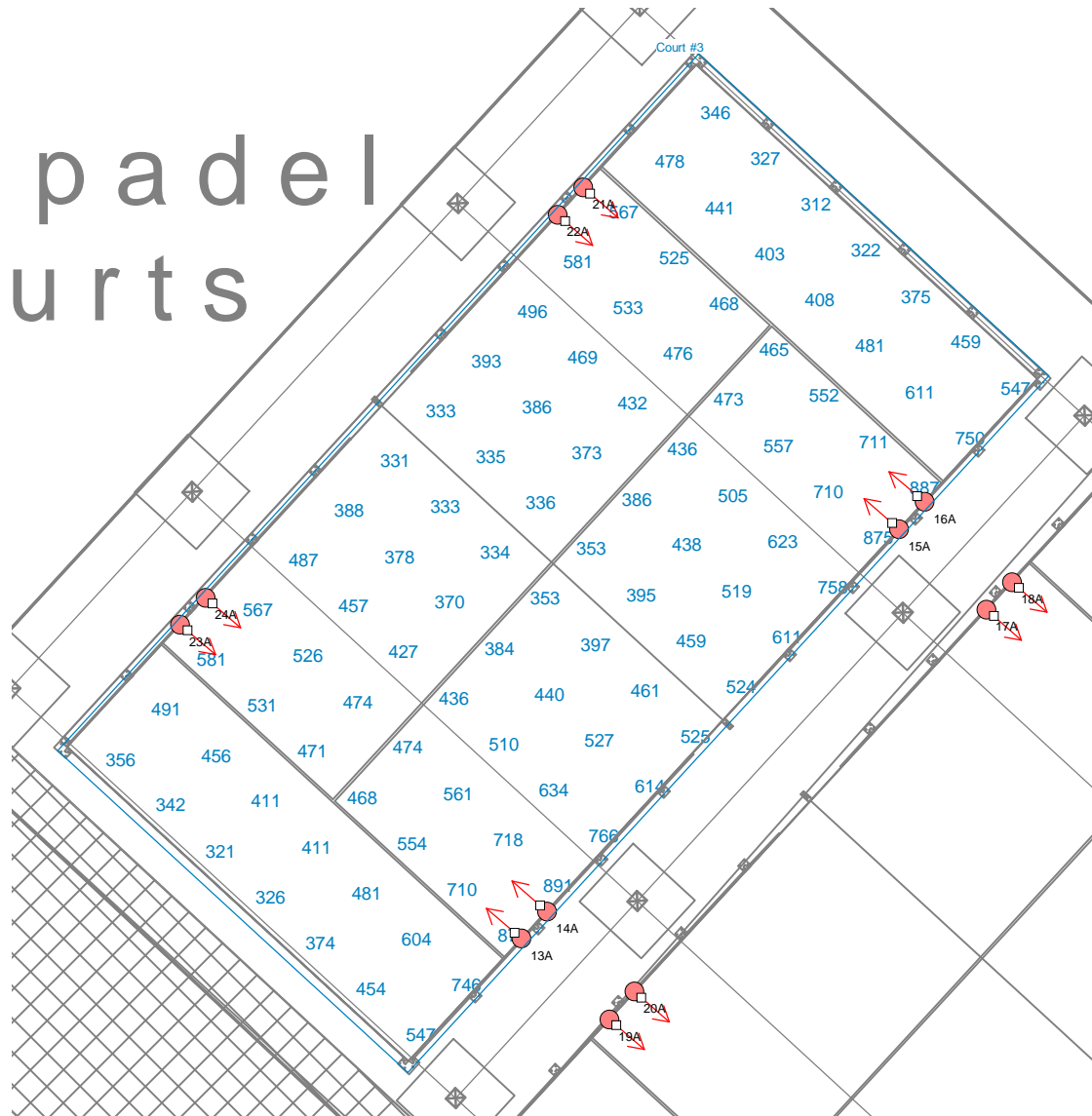

Results - cumulative all three courts lit, Maintenance factor 1

Eav	494.65
Emin	311.70
E _{max}	890.54
E _{min} /E _{max}	0.35
E _{min} /E _{av}	0.63

Appendix D – AutoCAD Drawing showing Design Details and Outputs

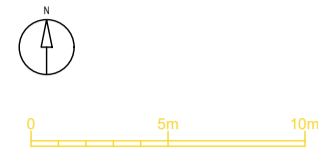

Exterior Lighting Design

Miller Goodall Ltd
Ashworth House
Deakins Business Park
Egerton
Bolton
BL7 9RP
Tel: 01204 596166
E-mail: info@millergoodall.co.uk
www.millergoodall.co.uk

The lighting design has been prepared for the development planning application. The design is subject to comment and approval by the local authority and/or overseeing organisation. **It is a preliminary design not for construction.**

Installation is subject to technical approval and sign off.

The design has been prepared in accordance with Construction Design Management Regulations 2015, Part 3 Health and Safety Duties and Roles, Duties of Designer.

See the accompany lighting impact assessment and Reality Outdoor model outputs for details of relevant CDM risks and technical details of the prepared lighting design.

Installation constraints associated with civil, electrical and engineering disciplines require further consideration post-planning and before installation. Installation and constraints must be identified in accordance with specific standard, British Standards relevant to the discipline.

The lux drawing shows the outputs for maintenance factor 1.

Lighting standard
Lawn Tennis Association Padel Courts Data Sheet
Average Horizontal Lux: 300
Uniformity: 0.5 (50%)

Specification
Product: FILUX FT21200 (F-2144)
Colour Temperature: 4000K
IP65
Watt: 200W
Tilt angle: 0 degree
Install height: 6 m
Mounting: Stirrup bracket on column

1	30/06/2025	Initial Issue	PW	PW
Rev.	Date	Purpose	Drawn by	Approved by

MILLER GOODALL
ACOUSTICS - AIR QUALITY - LIGHTING
Project: Haverhill Padel Courts, The New Croft, Chalkestone Way, Haverhill CB9 0BW

Client: Red Raven Solutions Limited

Scale @ A1: 1:7 Project Number: 103353

Statistics (lux). MF1				
Grid Number	Task Area	Avg	Min	Min/Avg
	Court In-isolation	383	258	0.67
Cumulative - all 3 courts lit				
1	Court 1	494	318	0.65
2	Court 2	600.00	382	0.64
3	Court 3	495.00	312.00	0.63
4	Chalkstone Way ESR	Max V-lux (MF1.0): 0.31		

Product	Symbol	Height (m)	Type & Optic	Lumen Output (flux km)	Wattage	Quantity
Filux F-21200		6	Post-top, Floodlight, symmetrical	26	200	24

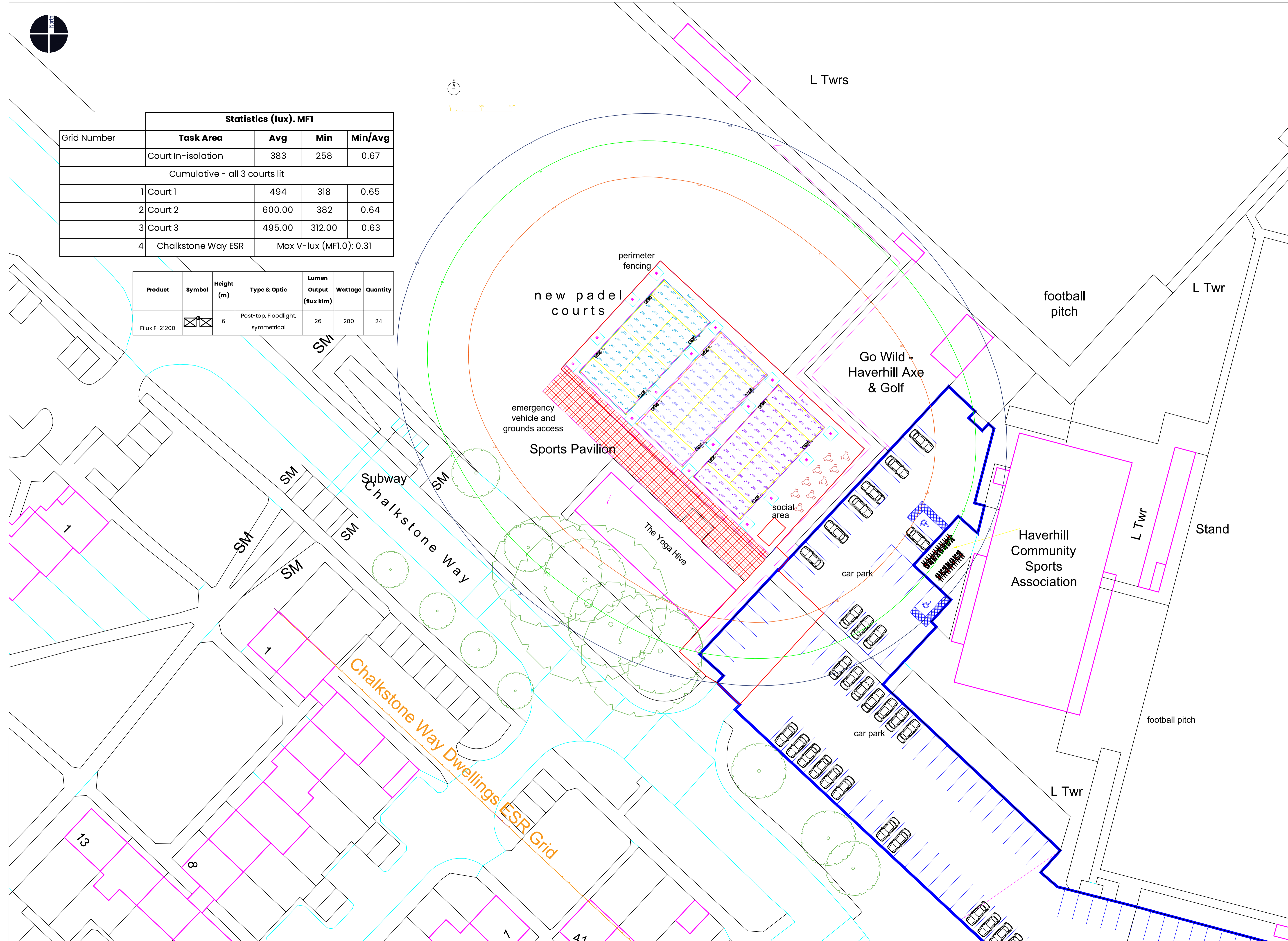

Glossary of Terms

Arrangement The pattern in which the luminaires are sited in plan (e.g. regular, along one edge or around the perimeter, staggered, opposite etc).

Average Illuminance Illuminance (lux) averaged over the specified area, road

Average Luminance Luminance (cd/m²) averaged over the specified area or solid angle

Base Plate [of the lighting column] Plate below ground level fixed to a planted lighting column to prevent the column sinking into the ground and to help prevent the column overturning

Beam Angle The total angle over which the luminous intensity of a beam drops to 50% of the peak value

Bracket A component used to support a luminaire at a definite distance from the axis of the lower straight position of a column

Calculation Grid A series of calculation grids set out in grid formation. Modelled at 1.5 * 1.5 m grid spacing.

Candela SI unit of luminous intensity (cd).

Carriageway That part of the road normally used by vehicular traffic

Colour Appearance The apparent colour of light emitted by a particular light source – often expressed in terms of ‘cool’ (4000 Kelvin (K)), ‘intermediate’ (3500 K) and ‘warm’ (3000 K). These terms are generalisations but are commonly used to describe light colour appearances

Colour Rendering Index (Ra) Measure of the degree to which the colour and appearance of an object appears ‘naturally’ when compared to a basis of reference e.g. artificial light, daylight.

Colour Temperature Temperature of the light measured in Kelvin (K)

Conflict Area Areas where different classes mix or cross. Examples such as road intersections, roundabouts, queuing locations, pedestrian crossings.

Contrast The difference in appearance of two or more parts of a field seen simultaneously or successively. E.g. brightness contrast, one object appearing more in dark than the other.

Curfew The time after which stricter requirements will apply. Planning conditions covering hours of operation or cessation lighting post-curfew will often be specified by a planning authority. There is no set definition of curfew and it can vary by location, however, 23:00 to 07:00 is often cited.

Disability Glare Glare that impairs the vision of objects without necessarily causing discomfort

Discomfort Glare Glare that causes discomfort without necessarily impairing the vision of an object

District Network Operator (DNO) The company responsible for the distribution of electrical energy in a predefined area

Environmental Zone Designated zone (area) where additional controls on exterior lighting are imposed

Glare Condition of vision in which discomfort or a reduction in the ability to see details or objects, caused by unsuitable distribution or range of luminance, or to extreme contrast

Horizontal Illuminance The illuminance on a horizontal plane at a specified height (ground level, unless otherwise specified)

Illuminance The amount of light (lumens) landing on a surface area. Measured as lux. The lighting of surfaces, object or surroundings so they may be seen

Light Pollution The spillage of light into areas where it is not desired

Light Trespass Light, normally measured in illuminance (lix) that impacts onto a surface outside of the area designed to be lit by the installation concerned

Lighting Column Support intended to hold one or more luminaires, consisting of a post, possibly an extension piece and a bracket.

Louvre Shield fitted to the luminaire exterior to reduce light in a particular direction. Used to reduce spill light.

Lumen SI unit of luminous flux. Luminous flux emitted in unit solid angle (steradian) by a uniform point source having a luminous intensity of 1 cd

Luminaire Apparatus which distributes, filters or transforms the light transmitted from one or more lamps. The light source i.e. LED

Luminance The amount of light that reaches the eye by reflection or direct transmission from an area

Lux SI unit of illuminance

Maintenance Factor The depreciation of light from a luminaire over the life cycle of it

Obtrusive Light Light outside the area to be lit that causes annoyance, discomfort, distraction or a reduction in the ability to see essential information e.g. at signal lights

Photometer Meter used to measure light. Minolta T10 is used by Miller Goodall Ltd to record illuminance (lux) levels

Sky Glow The brightening of the night sky that results from the reflection of radiation, scattered from the constituents of the atmosphere (e.g. gaseous molecules, aerosols and particulate matter), in the direction of observation

Spacing The distance between luminaires in an installation

Spill Light (stray light) Light emitted by an installation, which falls outside the boundaries that is being lit

Threshold Increment (TI) Measure of the loss of visibility caused by the disability glare of luminaires of a road lighting installation

Uplighter A light placed or designed to throw illumination upwards, usually for architectural purposes

Upward Light Ratio (ULO) Proportion of the light flux of a luminaire and/or installation that is emitted at and above the horizontal when the luminaire is mounted at an installation position. A measurement of sky glow.

Vertical Illuminance The illuminance on a vertical plane at a specified point.

